



CDVI

31, av. du Gal Leclerc
 93500 PANTIN FRANCE
 Tel : 33 (0)1 48 91 01 02
 Fax : 33 (0)1 48 91 21 21
 www.cdvi.com

DC100E

BACK-LIT KEYS KEYPAD
 100 USER CODES - FLUSH MOUNT

INSTALLATION



The DC100E keypad exists also in 2 and 3 relay outputs (DC100E2R, DC100E3R). Refer to page 9 of this manual for information on 2 and 3 relay outputs.

The visual feedback with the green and red LED's is always active. It is possible to activate the audible feedback by putting ST1 jumper on (see page 6).

Rating
IP 54



MOUNTING KIT

Qty	Description	Schéma
1	M5 TORX® spanner	
1	05D 680K varistor	

Dimensions: - Face plate: 200 x 120 x 16 (mm)
 - Back casing: 170 x 95 x 35 (mm)

I. PRODUCT INFORMATION

A. Technical Features (1 relay output)

Input voltage 12V to 24 VAC
 12V to 48 VDC
 12-digit backlit keys keypad
 Visual feedback (Green and Red LED's)
 EPROM memory storage
 100 user codes programmable in 4 to 6-digit code length
 1 relay output N/O and N/C contact 8A @ 250V
 Master code programmable in 4 to 6-digit code length
 Audible feedback
 1 request-to-exit input
 P2 jumper: Reset to default master code and delete all user codes
 P3 jumper: User code modification by user active

B. Factory Default Values

Back-lit time: 10 seconds
 Time relay output: 1 second
 Code length: 5-digit
 Master Code: 12345
 Programming mode time: 120 seconds
 Sub master code for user code modification by user: A and B
 Red LED's lights on when keypad is powered.

C. Audible Feedback

1 short beep	Keypad powered
1 long beep	Programming validated and relay activated
2 short beeps	Enter or Exit from programming
4 short beeps	Data computing error

D. Code length

All the keypad keys can be used to program a code.
 The master code and the Pin code can be in 4 to 6-digits.
 The master code CAN NOT be used as a user code.
 Codes 000000, 00000 and 0000 can only be used to delete a user code. To delete a User Code enter the user number (location number) then enter 0000 if the code length is in 4-digit format, enter 00000 if the code length is in 5-digit format.

E. Request-to-Exit Input

This normally open loop that operates upon activation relay 1 (DC100E, DC100E2R or DC100E3R) or relay 2 (DC100E 2 or 3 relay version). This feature is especially useful when controlling a lock.

P1 input activates relay 1 (the time output is programmable).

H1 input can be used with a timer to allow free access by pressing on any key from the keypad. If the timer contact is open then the free access is deactivated. If the timer is closed then the free access is activated.

H2 input can be used with a timer to allow free access by pressing on the push button.

F. Current Draw (keypad only)

12V AC: 20 mA in rest, 100 mA max when all 3 relays are energized
24V AC: 10 mA in rest, 50 mA max when all 3 relays are energized

II. PROGRAMMING

A. Erase Keypad Memory / Reset Keypad to Factory Default Values

1. Enter the master code twice (12345 default value master code).
2 beeps are emitted to confirm entry in programming mode.
2. Press A6. The green LED's lights on during 1 second. Press on A and B to start the reset. The LED's lights on solid green. Wait until the green LED's lights off. The reset is then completed when the red LED's lights on and then lights off.
The keypad exits from programming mode and the default values are restored.

A6

OR

1. Cut the power off the keypad. Put P2 jumper.
2. Power the keypad. The green LED's lights on. Wait a few seconds, one beep is emitted. The green LED's lights off. Remove P2 jumper.
3. The keypad is set to the default values.

P2

B. Programming the Code Length

1. Enter the master code twice (12345 default value master code). The red LED's light on to confirm entry in programming mode.
2. Press A4 to program the code length. The green LED's light on during 1 second. Press 4 for a 4-digit code, press 5 for a 5-digit code or press 6 for a 6-digit code. The green LED's light on for 1 second to confirm the new code length.
3. Press A5 to program the master code. The green LED's light on during 1 second. Enter the 4, 5 or 6-digit new master code. The green LED's light on during 1 second to confirm the new master code.
4. Press B to exit from programming mode. The red LED's light off to confirm that the keypad is in stand-by operating mode.

A4

Red LED's flashing time indicates a data computing error.

[Master code or user code: 12369
Changing to a 4-digit code: Enter 2369

[Master code or user code: 12369
Changing to a 6-digit code: Enter 012369

Set the code length first and then program the new master code.

C. Programming a New Master Code

1. Enter the master code twice (12345 default value master code). The red LED's light on to confirm entry in programming mode.
2. Press A5 to program the master code. The green LED's light on during 1 second. Enter the 4, 5 or 6-digit new master code. The green LED's light on during 1 second to confirm the new master code.
3. Press B to exit from programming mode. The red LED's light off to confirm that the keypad is in stand-by operating mode.

A5

D. ADDING, CHANGING OR DELETING A USER CODE

Group 1: from user number 00 to user number 99 activate relay 1

1. Enter the master code twice (12345 default value master code). The red LED's light on to confirm entry in programming mode.

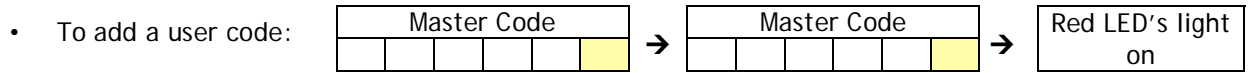

**00
to
99**

2. Enter the user number (00 to 99). If the user number is empty the green LED's light on during 1 second, enter the 4, 5 or 6-digit user code. If the user number is already programmed, the red LED's flash 4 times.

To *CHANGE* a user code enter the user number, the red LED's flash 4 times, enter the 4, 5 or 6-digit user code.

To *DELETING* a user code enter the user code (location) and then enter 000000 for a 6-digit code, 00000 for a 5-digit code or 0000 for a 4-digit code.

3. Press B to exit from programming mode. The red LED's light off to confirm that the keypad is in stand-by operating mode.

User Code List

00									
01									
02									
03									
04									
05									
06									
07									
08									
09									
10									
11									
12									
13									
14									
15									
16									
17									
18									
19									
20									
21									
22									
23									
24									
25									
26									
27									
28									
29									
30									
31									
32									
33									
34									
35									
36									
37									
38									
39									
40									
41									
42									
43									
44									
45									
46									
47									
48									
49									
50									
51									
52									
53									
54									
55									
56									
57									
58									
59									
60									
61									
62									
63									
64									
65									
66									
67									
68									
69									
70									
71									
72									
73									
74									
75									
76									
77									
78									
79									
80									
81									
82									
83									
84									
85									
86									
87									
88									
89									
90									
91									
92									
93									
94									
95									
96									
97									
98									
99									

E. Programming the Time Outputs

Enter the master code twice (12345 default value master code). The red LED's light on to confirm entry in programming mode.

A0

2. Press A0 to program the key-in keypad time and the backlit keys time. The green LED's light during 1 second. Enter the time in second - 10 for 10 seconds up to 99 for 99 seconds. For permanent backlit enter 00. The green LED's light on during 1 second to confirm the time validation.

A1

3. Press A1 to program the time relay output. The green LED's light on during 1 second. Enter the time in seconds - 01 for 1 second up to 99 for 99 seconds. Enter 00 for a toggled output. The green LED's light on during 1 second to validate the time programmed.

4. Press B to exit from programming mode. The red LED's light off to confirm that the keypad is in stand-by operating mode.

Red LED's flashing 4 times indicates a data computing error.

F. Reset Master Code to Factory Default Value

Place the jumper on P2 in the back of the keypad. The green LED's light on and one beep is emitted. Wait for the green LED's to light off. Remove jumper from P2. The master code is reset to default setting 123456 in 6-digit code, 12345 in 5-digit code or 1234 in 4-digit code.

G. Enable/Disable user code modification by user

P3

The Sub Master code allows the user to change its own code without having to enter in programming mode. For security reasons the code need to be changed periodically. This feature makes it easier and faster for the user to change its user code.

Place the jumper on P3 to enable user to reprogram its own user code.

Remove the jumper from P3 to disable the user to reprogram its own code.

1. Enter the old user code. The relay is activated and the green LED's light on.
2. Enter immediately the 2-digit sub master code (A and B Factory Default Value). The red LED's light on.
3. Enter the new user code. The green LED's light on during 1 second, the new user code is programmed. The red LED's light off.
4. Enter the new user code to verify.

H. Programming a Sub Master Code

A7

1. Enter the master code twice (12345 default value master code). The red LED's light on to confirm entry in programming mode.
2. Press A7 to enter in sub master code menu. The green LED's light on during 1 second. Enter the new sub master code. The green LED's light on during 1 second to confirm programming of the new sub master code.
3. Press B to exit from programming. The red LED's light off to confirm exit from programming.

Wiring Diagram DC100E: 1 relay output

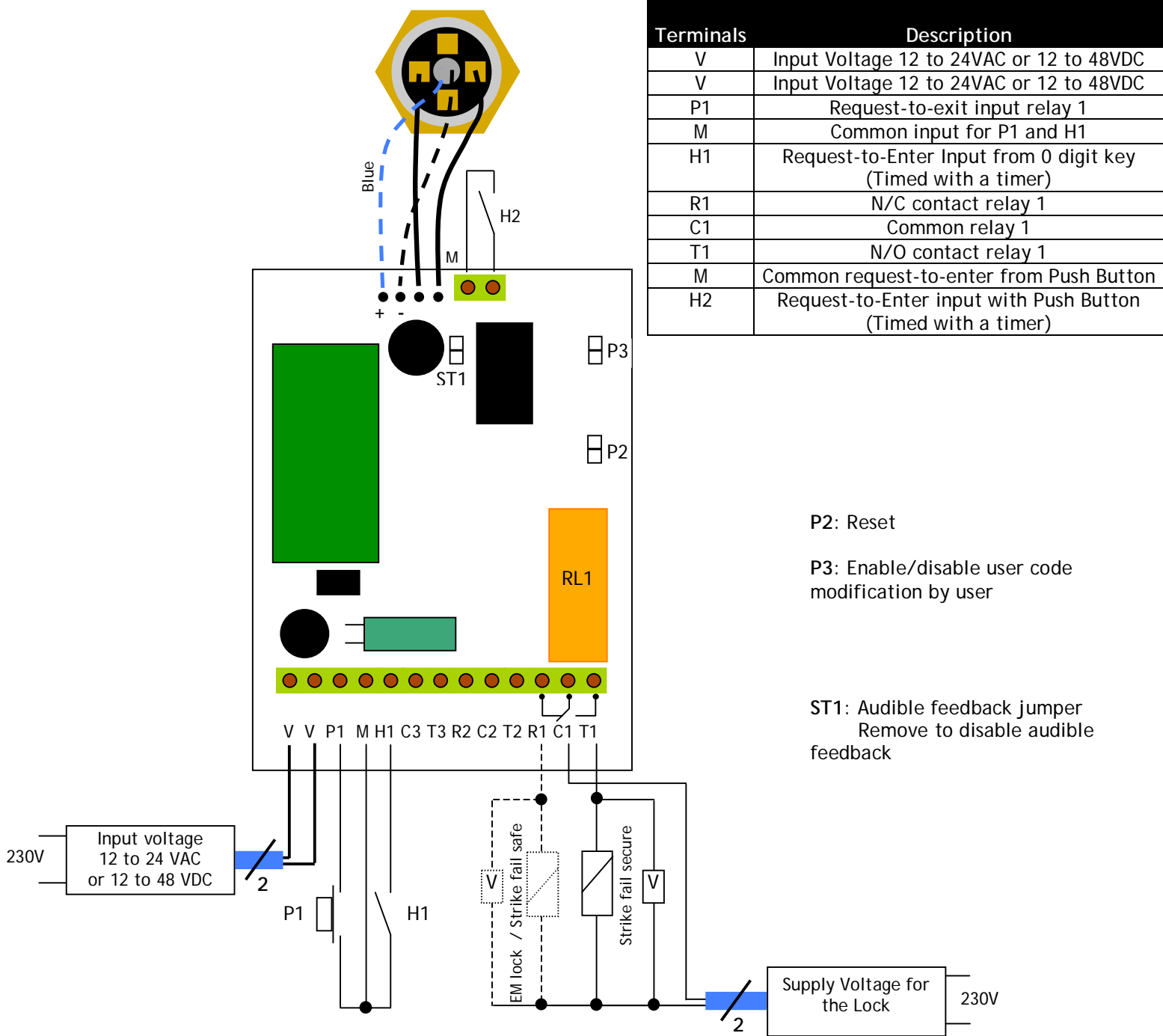

V : Varistor

This device comes with a varistor. The varistor must be connected on the strike terminal (electromagnet...) operated by the device. If this product operates more than one strike, each lock should have a varistor. The varistor controls the overload produced by the strike coil - back emf. It is recommended to use a separate power supply when using a Shear Lock Magnet.

Wiring Diagram DC100E2R and DC100E3R : 2 and 3 relay outputs

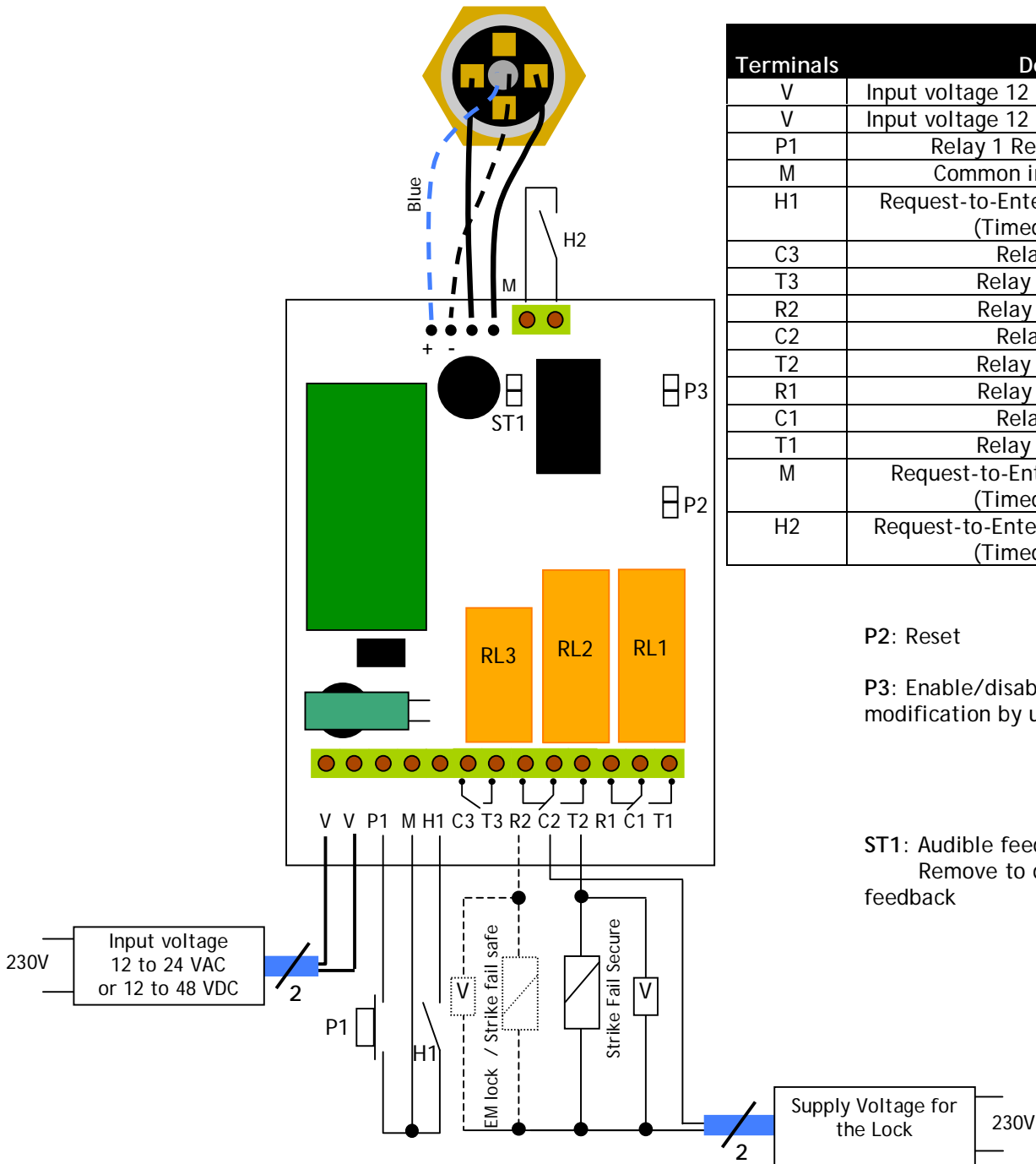

Terminals	Description
V	Input voltage 12 to 24VAC or 12 to 48 VDC
V	Input voltage 12 to 24VAC or 12 to 48 VDC
P1	Relay 1 Request-to-Exit input
M	Common input for P1 and H1
H1	Request-to-Enter Input from 0 digit key (Timed with a timer)
C3	Relay 3 common
T3	Relay 3 N/O contact
R2	Relay 2 N/C contact
C2	Relay 2 common
T2	Relay 2 N/O contact
R1	Relay 1 N/C contact
C1	Relay 1 common
T1	Relay 1 N/O contact
M	Request-to-Enter input (Push button) (Timed with a timer)
H2	Request-to-Enter input with Push Button (Timed with a timer)

P2: Reset

P3: Enable/disable user code modification by user

ST1: Audible feedback jumper
Remove to disable audible feedback

V : Varistor

This device comes with a varistor.

The varistor must be connected on the strike terminal (electromagnet...) operated by the device.

If this product operates more than one strike, each lock should have a varistor.

The varistor controls the overload produced by the strike coil - back emf.

It is recommended to use a separate power supply when using a Shear Lock Magnet.

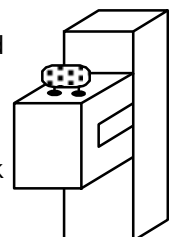

I. Enable/Disable Audible Feedback

The audible feedback is always enabled in programming mode or when the relay is energized.

To **ENABLE** the audible feedback at the press of any key:

1. Enter the master code twice (12345 default value master code).
The red LED's light on to confirm entry in programming mode.

AA

2. Press AA. One beep is emitted. **Enter 1 to ENABLE** the audible feedback at the press of any digit key, 1 beep is emitted to confirm the new set up.

To **DISABLE** the audible feedback at the press of any key:

3. Press AA. One beep is emitted. **Enter 0 to DISABLE** the audible feedback at the press of any digit key, 1 beep is emitted to confirm the new set up.
4. Press B to exit from programming. 2 beeps are emitted.

J. Additional Programming DC100E2R and DC100E3R (2 and 3 relay outputs)

DC100E2R 2 relay outputs: 2 relays N/O and N/C contacts 8A @ 250V~

Group 1: From user number (location) 00 to user number 59, relay 1

Group 2: From user number (location) 60 to user number 99, relay 2

A2

Output time for relay 2 Press A2

A8

Programming a new sub master code Press A8 (Default 1 & 3)

DC100E3R 3 relay outputs: 2 relays N/O and N/C contacts 8A @ 250V~
And 1 relay N/O contact T 6A @ 250V ~

Group 1: user number (location) 00 to user number 59, relay 1

Group 2: user number (location) 60 to user number 79, relay 2

Group 3: user number (location) 80 to user number 99, relay 3

A3

Output time for relay 3 Press A3

A9

Programming a new sub master code Press A9 (Default 4 & 6)

DC100 Mounting Instructions

- ① Prepare a cavity in the wall (170H x 95L x 35P) to mount the back casing of the DC100E and drill a hole for the cable.
- ② Seal the back box and make sure to flush mounted it with the wall. 
- ③ After connecting the cable to the DC100E keypad, test a user code the push button and make sure the LED's light on, as well as the buzzer is working. Place the DC100E keypad on the back box.
- ④ Tighten the screw at the bottom of the keypad with the spanner (TORX® spanner for M5 screw).

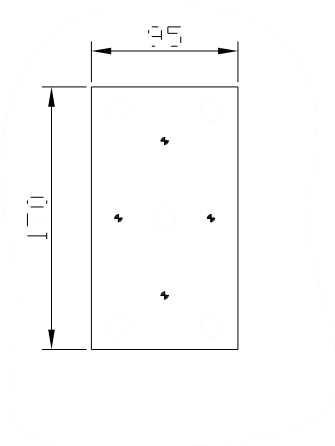

①

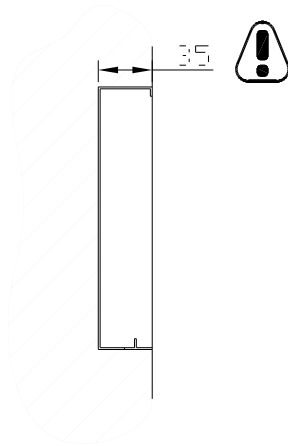

②

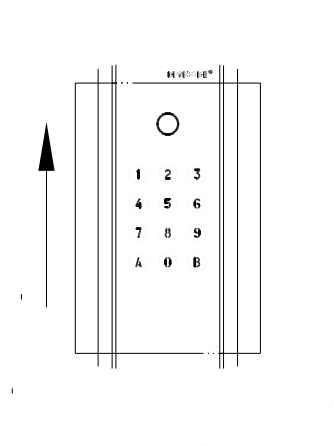

③

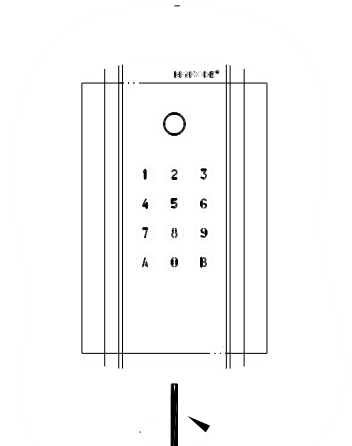

④

Template

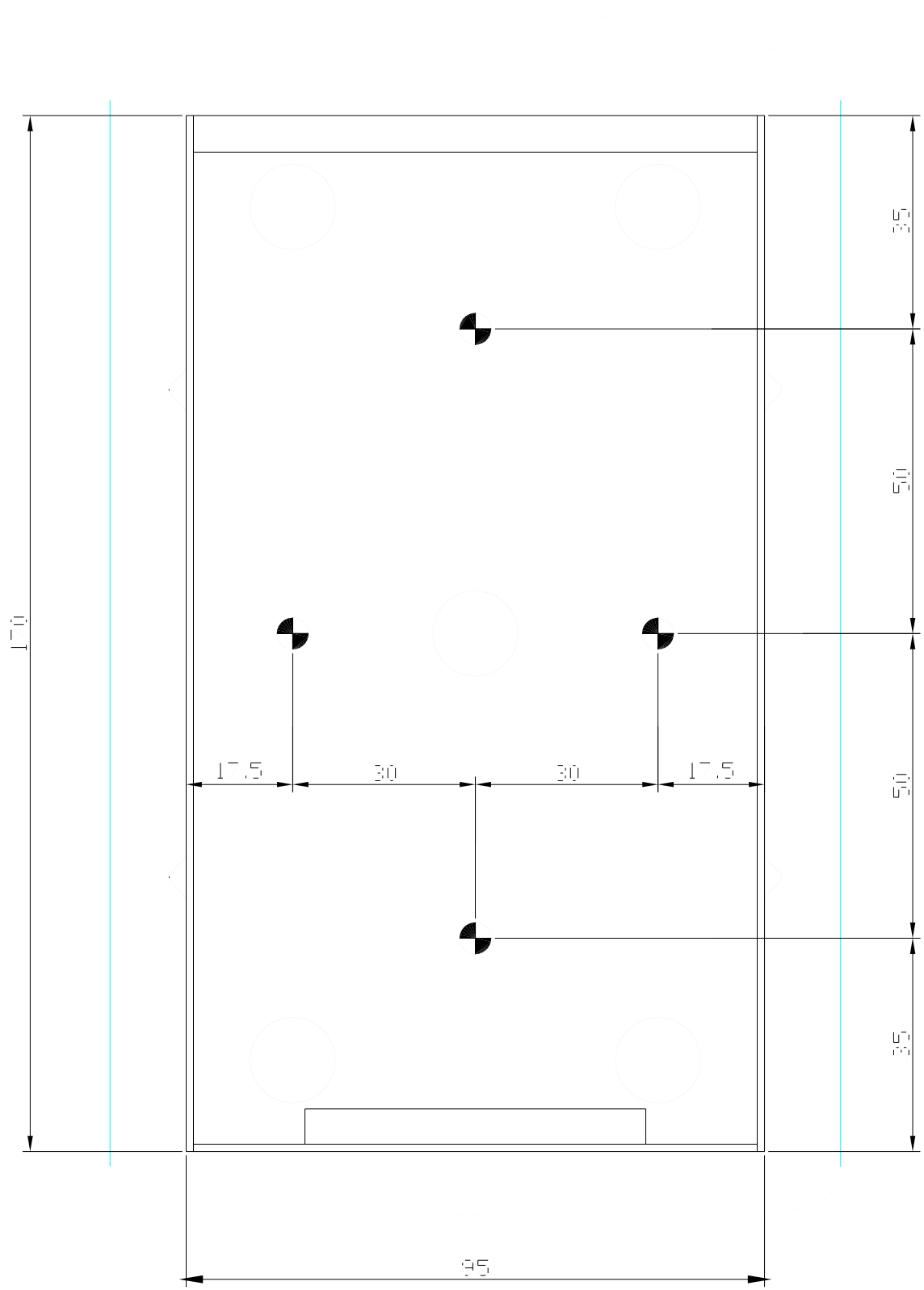

Scale 1:1