



# KCIL100/2 RELAY

## LIT KEYPAD REMOTE CONTROLLER 100 USER CODES

### Wiring diagram

Wiring Diagram and Instruction

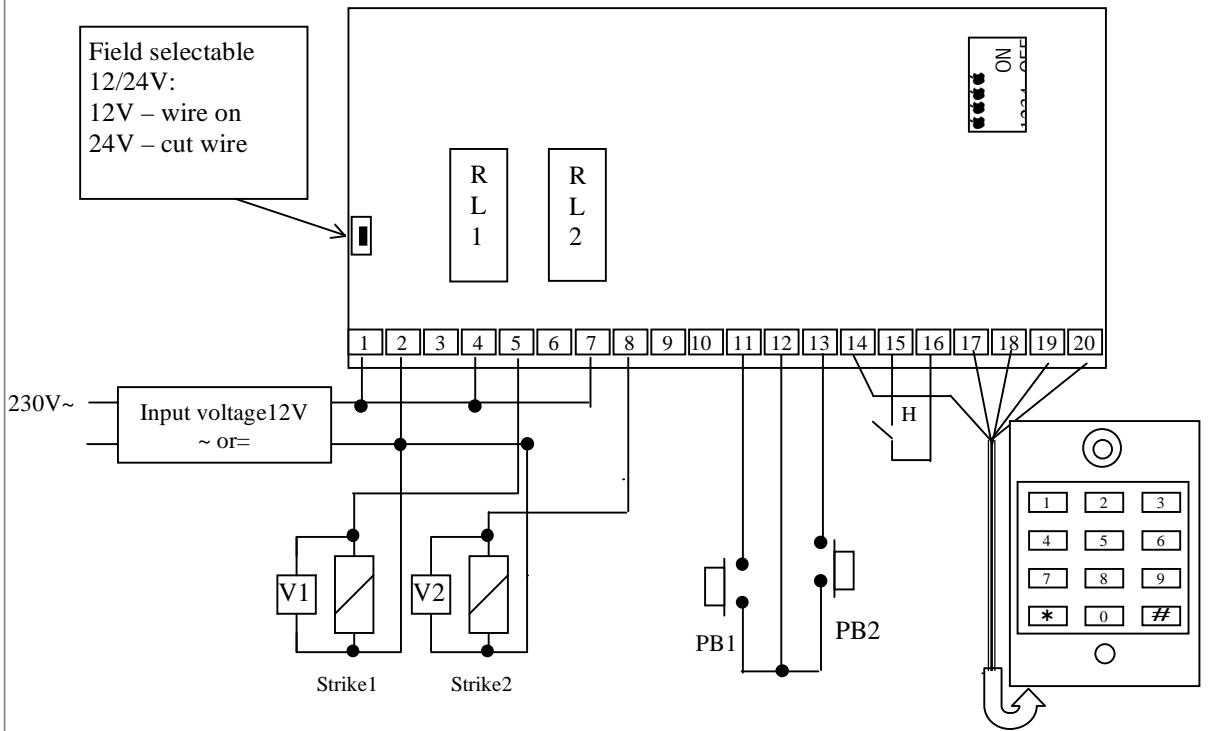

1	Input voltage 12 VAC/DC	11	Request-to-exit input PB 1
2	Input voltage 12 VAC/DC	12	Common of PB1 and PB2
3	[R] N/C contact RL 1	13	Request to exit PB2
4	[C] Common RL 1	14	External push button PB (Blue) r
5	[T] N/O contact RL 1	15,16	Timer clock contacts: Open – External PB disabled Closed – External PB activates RL 1
6	[R] N/C contact RL 2	17	Cable (white) keypad
7	[C] Common RL 2	18	Cable (brown) keypad
8	[T] N/O contact RL 2		

This device comes with a varistor.  
The varistor must be connected to the strike terminal (electromagnet...) operated by the device.  
If this product works with many strikes, each of them should have a varistor.  
The varistor controls the overload produced by the strike coil – back emf.

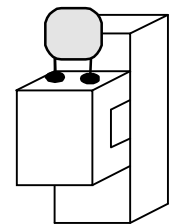

If you are using a « Shear Lock » electromagnetic lock, it is recommended to use a separate power supply than the one connected to the KCIL100!

## Technical specifications

Input voltage	12 V or 24 V ~ or = <b>(Do not use the latched output in 24V!)</b>
Outputs	2 relay outputs 2 N/O & N/C contacts 8amp/250V
Operating temperature	-20°C to +50°C
User code	100 programmable codes
User modification code	2-digit user modification code
Master code	1 programmable master code
Code length	4 or 5-digit user code and master code
Push buttons	2 request to exit input and 1 external push button
Keypad	12-digit keypad with built-in buzzer (audible signal) and 1 external push button
Push button	2 Request-to-exit inputs and an external push button (control by the contact timer)
Distance between keypad and remote controller	maximum 10 meter

## Default values

Master code:	1234 in 4-digit code or 12345 in 5-digit code
Relay time delay:	1 second
Key-in Keypad:	10 seconds
Programming delay:	120 seconds (2 minutes)
Code of modification:	*and # for relay 1 13 for relay 2

## Code length

The master code and user codes can be of 4 or 5 digit code (dipswitch n° 3).

All the digit keys can be used to program a user code (0 to 9, \* and #).

The master code cannot be used as a user code.

The 4-digit code 0000 and the 5-digit code 00000 are used to delete an existing user code and then cannot be used as user codes.

## Push buttons

The request to exit input PB1 activates relay 1 RL1

The request to exit input PB2 activates relay 1 RL2

The contact of the timer allows using the external push button at scheduled hours:

Timer clock contact open - External push button non available,

Timer clock contact closed - External push button activates relay 1 RL1

## Dipswitches

DIP-SWITCH	ON	OFF
1	Programming by the user disabled	Programming enabled
2	Programming from keypad disabled	Programming enabled
3	4-digit user code	5-digit user code
4	Programming of master code enabled	Programming disabled

### Setting a new master code

1. Select the user code length with dipswitch n° 3 (ON for a 4-digit code or OFF for a 5-digit code).
2. Put dipswitch No. 4 ON.
3. Enter the 4 or 5-digit master code (according to dip-switch n° 3 position) for a new master code. An audible sound confirms that the new master code is accepted.
4. Put back dipswitch n° 4 in position OFF to exit from programming mode and go back to a standby mode.

### User number group

GROUP	USER NUMBER	RELAY	PROGRAMMING CODE
1 (60 user codes)	from 00 to 59	RL1	*1
2 (40 user codes)	from 60 to 99	RL2	*2

### Setting User Codes and Time Delays

1. Put dipswitch No. 2 OFF to enter into programming mode.
2. Enter the master code twice (for the first use the master code default value is 1234 or 12345). 2 audible beeps confirm entry in programming mode.
3. Enter the user number (from 00 to 99), then the 4 or 5 –digit user code (see board on the next page). An audible sound beep indicates that the code has been accepted.
4. Enter \*1 (door release time for RL1) then the time output in seconds – 01 for 1 second up to 99 for 99 seconds. For a latched output time enter 00.
5. Enter \*2 (door release time for RL2) then the time output in seconds – 01 for 1 second up to 99 for 99 seconds. For a latched output time enter 00.

#### **Do not use the latched output in 24V!**

An audible beep sound to confirm that the time delay has been accepted.

6. Enter \*0 (key-in keypad delay) then the time delay in seconds – 10 for 10 seconds up to 99 for 99 seconds.
7. Enter \* 9 (user modification code for relay 1), then the 2-digit code. An audible beep sound to confirm that the new user modification code has been accepted.
8. Enter \* 8 (user modification code for relay 2), then the 2-digit code. An audible beep sound to confirm that the new user modification code has been accepted.
9. To exit from programming, press #. 2 beeps sound to confirm that you left the programming mode.
10. Put dipswitch n° 2 back to position ON (to disable the programming mode).

4 beeps indicate a data computing error.

### Setting user codes

- To set a new master code:

Set the code length by selecting the position on dipswitch n° 3 (ON for a 4-digit code, OFF for 5-digit code).

Dip-switch No. 4 ON

New master code

Dip-switch No. 4 OFF
One audible beep

- Setting new user codes. Put dipswitch No. 2 OFF.

Master Code

Master Code

Two audible beeps
-------------------

### User codes

00						01						02						03					
04						05						06						07					
08						09						10						11					
12						13						14						15					
16						17						18						19					
20						21						22						23					
24						25						26						27					
28						29						30						31					
32						33						34						35					
36						37						38						39					
40						41						42						43					
44						45						46						47					
48						49						50						51					
52						53						54						55					
56						57						58						59					
60						61						62						63					
64						65						66						67					
68						69						70						71					
72						73						74						75					
76						77						78						79					
80						81						82						83					
84						85						86						87					
88						89						90						91					
92						93						94						95					
96						97						98						99					

Time delay relay 1
* 1

Key-in keypad delay
* 0

User modification code
* 9

Time delay relay 2
* 2

User modification code
* 8

Press # to exit from the programming mode. Two beeps will sound to confirm that the keypad is in standby mode. Put dipswitch n° 2 back to ON.

Operator:		Date:
Building:		
N°:	Street:	
City:		
Other information:		

### Changing a PIN code by the user

Put dipswitch No. 1 ON to disable the modification of a code by the user or put dipswitch OFF to enable the modification of a code by the user.

1. Enter the user code. The relay is activated.
2. Enter immediately the 2-digit user modification code (for the first use the user modification code default is \* and # for relay 1 group 1 from 00 to 59). To modify a user code in group 2 from 60 to 99 enter user modification code 13).
3. Enter the new user code twice. Two audible beeps indicate that the new user code is accepted.
4. Enter the new user code to test it. The relay is activated.

If the new user code is not entered correctly, four beeps sound to confirm that the modification is not done.



# Template KCIL100

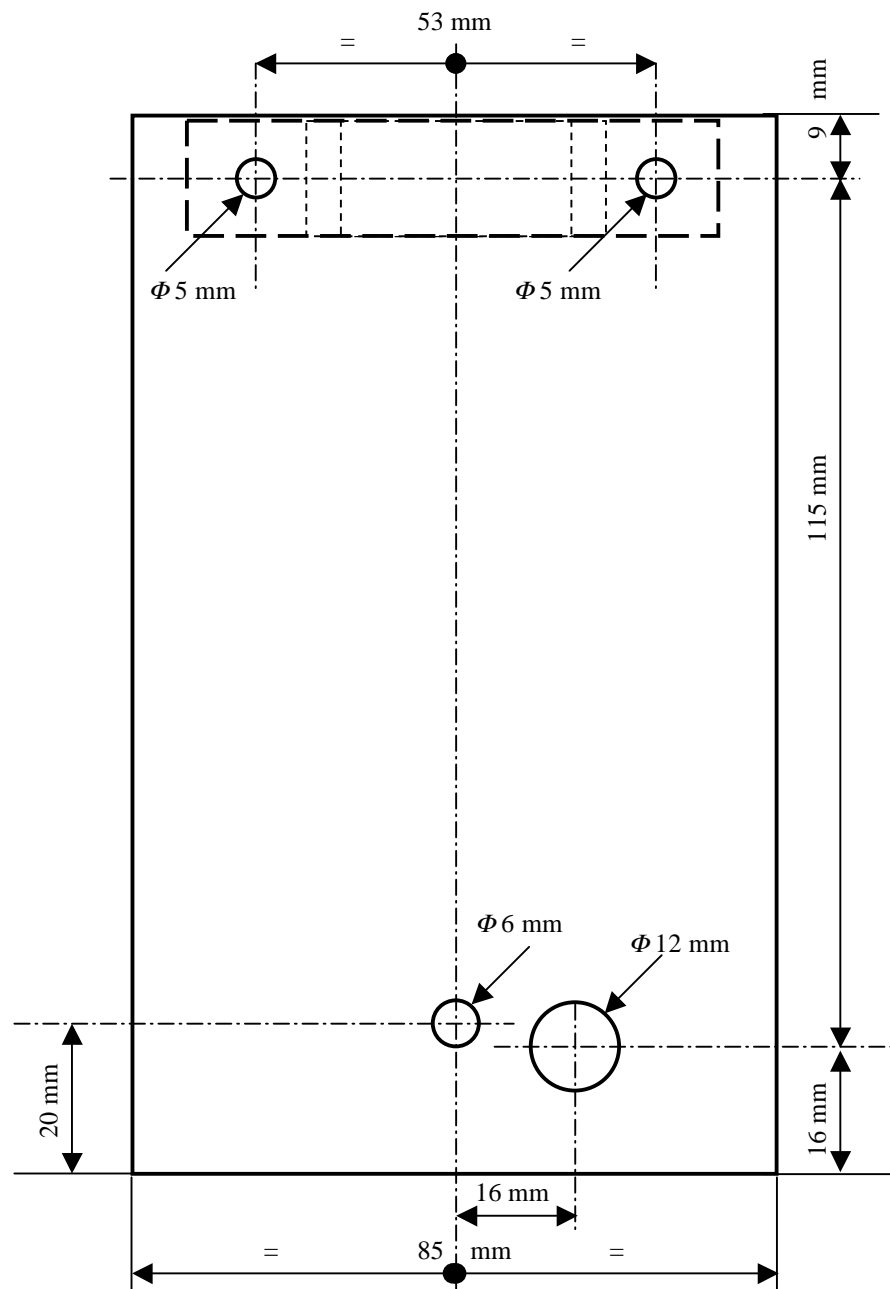

- 5 mm** diameter hole - for the bracket,
- 6-mm** diameter holes - for brass anchors,
- 12-mm** diameter hole - wiring access area.