



Edition: 06/09/2001 PDN345C

# PDN345/C/PROX

I.	<u>PRODUCT SPECIFICATION</u> .....	3
A.	Description .....	3
B.	System configuration.....	3
C.	Dip-Switches.....	4
D.	Reset of the Password .....	4
II.	<u>PROGRAMMING FROM FRONT PANEL</u> .....	4
A.	Setting a new resident .....	5
B.	Deleting a resident.....	6
C.	Modification of a resident.....	6
D.	Identification of a badge.....	7
E.	How to call a resident if using the directory list.....	7
F.	How to call a resident by its apartment number .....	7
G.	PIN Codes .....	7
H.	Using a Badge.....	8
III.	<u>SOFTWARE Installation</u> .....	8
IV.	<u>ProgramminG VIA THE pc</u> .....	11
A.	Modem .....	12
B.	Com Port .....	13
C.	Getting access to the Menu .....	13
D.	Password .....	13
E.	Menu.....	14
F.	Password .....	14
G.	Entry codes.....	15
H.	Time delays.....	15
I.	New & Edit resident file.....	16
1.	New resident .....	16
2.	Edit resident file.....	17
3.	Deleting a resident .....	19
J.	Resident List .....	19
K.	Stand by Message .....	20
L.	Badge Identification .....	20
M.	Access Control.....	21
V.	index .....	23
A.	C16D RELAY BOARD .....	23
B.	BCM/384.....	24
1.	Configuration of the relays on the mother board.....	24
2.	Configuration of the relays on the mother board.....	24
C.	Possible configurations .....	25
D.	Wiring diagram for BCM/384 .....	26
E.	Wiring diagram of C16D relay board and interface module BMU .....	27
F.	BMU Interface Module .....	28
G.	READER Terminals.....	29
1.	LED status.....	29
2.	16 point terminal.....	29
3.	3 point terminal 1,2, 3 & 4, 5, 6.....	30
a)	Contact Badge.....	30
b)	Keypad .....	30
c)	Proximity.....	31
d)	Infrared.....	31
e)	Proximity LMPI/D or LMP/D extended distance (50m max).....	32
f)	Magnetic stripe reader (format Clock & Data).....	32
4.	Jumper ST1 .....	33
a)	RF reader.....	33
5.	Jumper ST1 .....	33

- 6. Reader default values .....33
- 7. Reader set on the elevator board.....33
- H. Elevator Relay Board .....34
  - 1. Configuration of the elevator boards.....34
  - 2. Terminal .....34
- I. Badge Programming Unit.....35

## **I. PRODUCT SPECIFICATION**

### **A. Description**

- Input voltage 12VAC/DC.
- 2 lines 16 characters LCD display, Backlit.
- 12-digit keypad up lit.
- 4 buttons: Search name, call, and cancel.
- Built-in proximity reader.
- Output: 1 relay output N/O & N/C contact 8A@250V.
- Programmable time open delay.
- Programmable key-in keypad time delay.
- Programmable console time delay.
- Programmable time delay of elevator relay board.
- Stand-by message or running message.
- Up to 10 programmable PIN codes.
- Up to 345 apartments.
- 8 proximity badges per apartment total 2760 proximity badges maximum.
- Programming:
  - via front panel
  - via PC
  - via modem
- Possibility to add 4 readers of different technologies (contact badge (Dallas key), keypad, proximity, infrared, RF...)
- Possibility to connect different technologies.
- Up to 4-elevator relay board (total of 56 floors).
- Connection between the main panel, readers, relays boards and elevator relay board via bus RS485.
- Connection between the main panel and PC via RS232.

### **B. System configuration**

- The electronic directory can be connected to:
  - 20 C16D (relay board module on Din rail) operation up to 16 apartments each, 1 BMU interface module.
  - 2 BCM/384 (mother board unit in metal enclosure) the first unit control 192 apartments and the second unit 153.
  - 1 BCM/384 and C16D board as extension unit.
  - 4 access control readers.
  - 4 elevator relay boards (total 56 floor building)

- Supervisor entry code and entry code: 5-digit code starting by A or B as the first digit.
- Standby Message: 16 characters maximum
- Door open delay: 2 seconds default value
- Key-in keypad delay: 15 seconds default value
- Console unit time delay: 60 seconds default value
- Elevator relay board: 10 seconds up to 5 minutes

### C. Dip-Switches

- Dip 1: OFF elevator board disabled  
ON elevator board enabled
- Dip 2: OFF access control reader enabled  
ON access control reader disabled
- Dip 3: OFF normal mode  
ON
- Dip 4: OFF normal mode  
ON Supervisor Entry Code A1111

### D. Reset of the Password

Put dipswitch 4 ON during 1 second then switch it back to OFF.

The password is now set back to A1111 its default value.

## II. PROGRAMMING FROM FRONT PANEL

Once the panel is switched on, PDN 345 VER 3.2 message is displayed during 6 seconds, the message HELLO appears (default standby message).

Keypad:

<b>ABC</b> <b>1</b>	<b>DEF</b> <b>2</b>	<b>GHI</b> <b>3</b>
<b>JKL</b> <b>4</b>	<b>MNO</b> <b>5</b>	<b>PQR</b> <b>6</b>
<b>STU</b> <b>7</b>	<b>VWX</b> <b>8</b>	<b>YZ</b> <b>9</b>
<b>SP</b> <b>10</b>	<b>END</b> <b>11</b>	<b>VAL</b> <b>12</b>

Programming mode:

Enter the Password twice (A1111).

The message RESIDENT LIST is displayed.  
 Press on the B key to enter in the menu.  
 Press on the A key to identify a badge.  
 Press on CANCEL button to exit from programming.

## A. Setting a new resident

Once the B key has been depressed,  
 The message APARTMENT: is displayed.  
 Enter the apartment number 000 to 999.

The message NAME: is displayed.  
 Enter the name of the resident. After each letter entered press B to validate then press >

If dipswitch No.1 is ON

The message FLOOR No.: is displayed.  
 Enter the floor number 00 or 01 to 56 then press >

The message RELAY No.: is displayed.  
 Enter the relay number 001 to 345 then press >

If dipswitch No.2 is OFF

The message 4.3.2.1.P: 11111 is displayed.

- The first digit corresponds to reader No. 4,
- The second digit corresponds to reader No. 3,
- The third digit corresponds to reader No. 2,
- The fourth digit corresponds to reader No.1,
- The fifth digit corresponds to panel reader,

All the readers are authorized by default (1); replace the 1 digit by 0 to forbid the selected readers.

Press on the > button to keep the same value.

The message BADGE 1 is displayed

- Press B to display the following message.
- Press 0 to enter a badge, the sign flashes, present the badge.

The message BADGE 2 is displayed.  
 Repeat the same steps to program to other badges

The message APARTMENT: is displayed.

- Enter another resident.
- Press on CANCEL button to exit from programming.

The message PLEASE WAIT appears during a couple of seconds, and then the main menu is displayed.

## B. Deleting a resident

Select RESIDENT LIST and press on the B key, the message APARTMENT: is displayed.

Enter the apartment number to delete (example: 002).

The message APARTMENT: 002 is displayed.

- NAME: BROWN

Press A to delete the resident.

The message APARTMENT: is displayed.

Press on CANCEL button to exit from programming.

## C. Modification of a resident

Select RESIDENT LIST and press B;

The message APARTMENT:

Enter the apartment number (example 003).

The message APARTMENT: 003

NAME: SMITH

Is displayed and the flashes on the first letter of the name.

- Press 0 to modify the name: the old name is erased, then enter the new name and validate each letter by pressing on B then press > to display the next message.
- Press > to display directly the following message

If dipswitch No.1 is ON

The message FLOOR No.: 05 is displayed.

- Enter the new floor number then press >
- Press > to display directly the following message

The message RELAY No.: 003 and the flashes on the first digit:

- Enter the new relay number.
- Press > to access the badges

The message BADGE 1 is displayed followed by V if the badge stored

- Press B to keep the badge.
- Press 0 for a new badge.
- Press A to delete the badge.

Repeat the same steps to process the other badges

Press on CANCEL button to exit from programming.

## D. Identification of a badge

Enter the master code twice, scroll until the message RESIDENT LIST is displayed.

Press A, the message Present badge is displayed.

Present the badge in front of the reader of the directory panel, the message APARTMENT: XXX is displayed indicating to which apartment the badge belongs.

NOTE: If the Badge is not valide, the message UNKOWN BADGE is displayed.

- Press CANCEL to come back to the main menu
- Press A to identify another badge

In Standby mode:

- Press on the > button the first resident in the alphabetical order is displayed.
- Keep pressing on the > button to scroll the resident list.
- Press on the < button the last resident in the resident list is displayed.
- Keep pressing on the < button to scroll the resident list.

## E. How to call a resident if using the directory list

Once you have selected the resident name, press the CALL button Ω.

The message APARTMENT: XXX

- Calling is displayed.

If the relay board controls the elevator, the relay corresponding to the floor of the resident is activated to allow the visitor to access to the apartment by the elevator.

## F. How to call a resident by its apartment number

Enter the apartment number, the message:

- APARTMENT: XXX followed by the resident NAME is displayed.

Press CALL button to ring to the resident apartment.

NOTE: If the apartment number doesn't exist, the message INEXISTANT is displayed.

## G. PIN Codes

Once the first digit is entered "A" or "B", CODE is displayed. Enter the other 4-digit of the PIN code.

If the PIN code is valide: DOOR OPEN is displayed.

## H. Using a Badge

If the badge is valide: DOOR OPEN is displayed.

## III. SOFTWARE INSTALLATION

Insert the installation diskette in the floppy disk A, and then click on "**Start**»:



select "**Run**»:

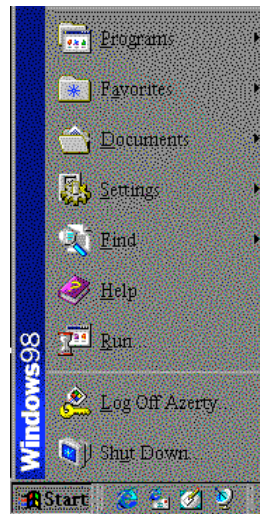

the following window appears:

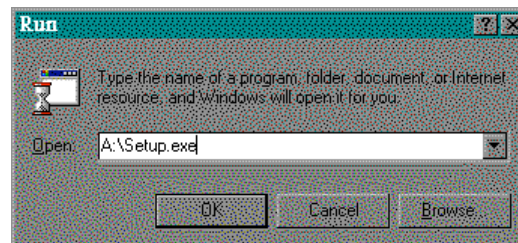

Enter "**A:\Setup.exe**", and click on **OK**.

The Install Shield Wizard Window appears:

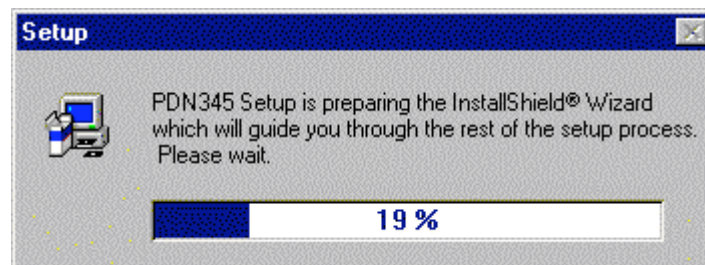

The Setup displays the next Window:

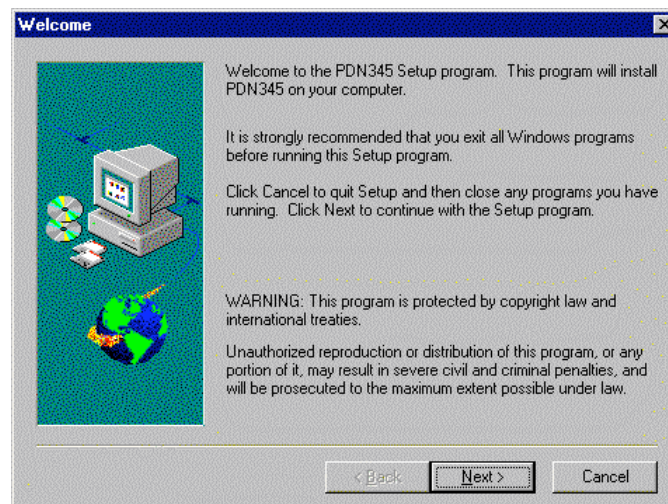

Click on "Next >".

The next window displays the license agreement, click on the "Yes" button to accept this agreement.

Enter your name and the company's name:

Name:

Company:

These two information are necessary if you want to continue the software installation. After entering the information click on the "Next" button.

The next window asks you to choose the destination directory where you want to install the new software. Click on "Next >" to keep the same directory destination, or click on "Browse..." to select another directory:

Destination Directory  
 C:\Program Files\ControleAcces\PDN345

click on the directory field

C:\Program Files\ControleAcces\PDN345

Then enter "\" and the name of the directory:

ram Files\ControleAcces\PDN345\Batiment1

and click "OK".

Since it is a new directory:

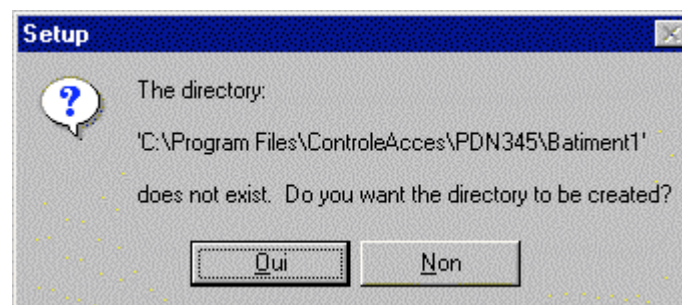

Click "Yes" to create the directory.

Back to the Destination Directory Window, click on "Next >".

The next window allows you to choose the program group, in which the icon will appear, keep the default value by clicking on "Next" button.

The next window displays the different option you have chosen; check all of them before clicking on "Next >".

The program is getting installed:

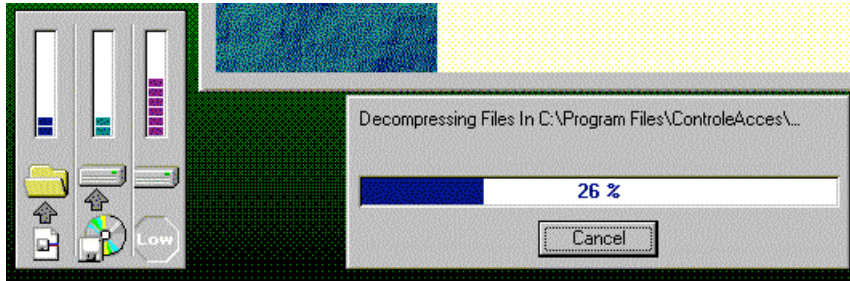

Setup is creating the Icons of the PDN/345/C/PROX:

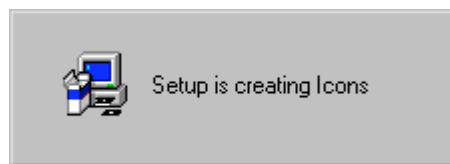

The Setup of the PDN/345/C/PROX software is now completed:

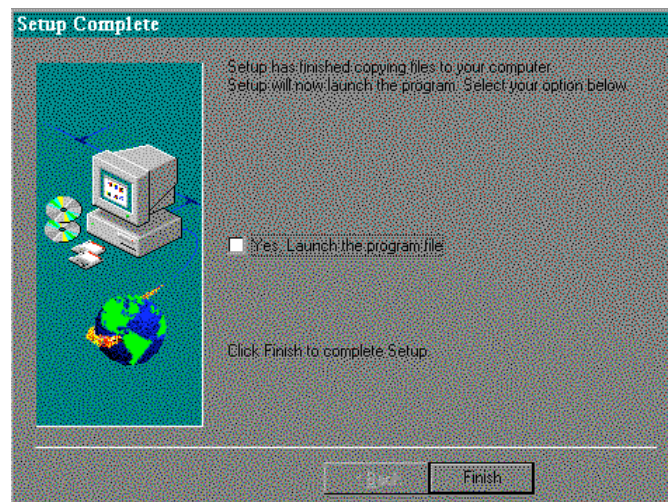

Click on the button "*Finish*"

Once the installation is completed, a minimized window is created and is next to "*Start*".

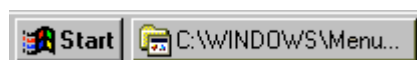

To open the window click on it, and click on Pdn345 to run the software,



To launch the UGM software, click on "**Start**" and select "**Program**"

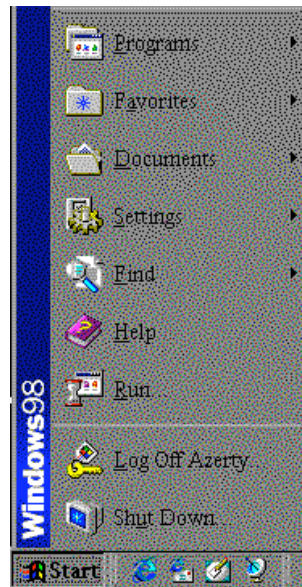

go to "Access Control" then select PDN345



#### IV. PROGRAMMING VIA THE PC

Two choices are available:

- The PC is connected directly to the Electronic Directory PDN/345/C/PROX by using the RS232 cable (see wiring diagram according to the system configuration).
- The PDN/345/C/PROX is connected to a modem and then the connection with the panel will be established by using a modem on the PC.

Launch the software PDN/345/C. Choose the language:



Click on the English flag or on the English icon.



**Figure 1: Home Page.**

Click on "Connection" icon to select the connection mode:



### A. Modem

To use a Modem connection click on:



Enter in the next window the telephone number:

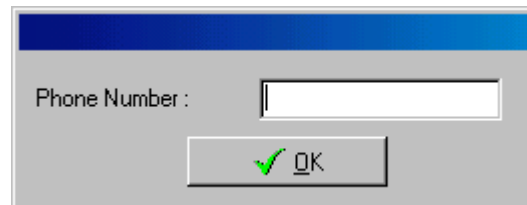

It is the telephone number to which the PDN/345/C is connected. Click on "Valid" to dial the number. Once the contact with PDN/345/C modem is established, select a COM port from your PC for the Badge Programming Unit (Enroller unit):



If you don't want to use the Programming Unit, click on the button:



Then, the icon "Menu" appears on the Home Page.

## B. Com Port

Choose a COM port according to your connection:

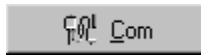

Then one Com port from the list (cf. Figure 2).



Figure 2: Com Port.

### Note:

The mouse usually uses COM1, COM3 and COM4 are not available from outside, a COM port connection behind the PC. These two COM ports are often used internally (a modem can use COM3).

## C. Getting access to the Menu

To open the Menu, click on “Menu” from the “Home Page”:



Or on the “M” key of the keyboard.

### Note:

- By pressing “Alt” and the underlined letter of the function from the menu, you can open the function.
- If the mouse is disabled, it will be possible to jump from function to function just by pressing on the ‘Tab’ button.

The communication between the PC and the Electronic Directory Panel is visualized by a level indicator (see Figure 3).

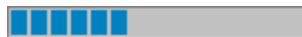
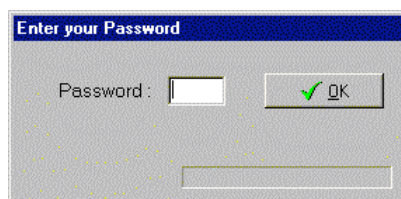

Figure 3: Level Indicator Bar.

Once the communication is completed the level indicator is full. Or if the level indicator is empty the communication isn’t established.

## D. Password

To get access to the Menu, a Password is requested:



The code is formed of one letter: 'A' or 'B', and of four number.

## E. Menu

From the menu you have access to different functions: Password, entry codes, time delays, new and edit resident, resident list, stand by message, badge identification and access control (cf. Figure 4).



Figure 4: Menu.

To go back to the home page click on the icon:



## F. Password

To modify the Password, click on the icon:

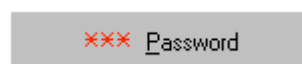

The old password is displayed:

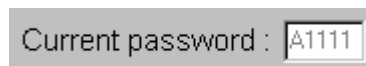

Click on modify,



Enter the new password and click the button



to save the password.

To go back to the menu click on

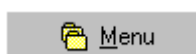

If you change the password and you click on menu without clicking on save the password remains unchanged

## G. Entry codes

To enter or modify an entry code, click on the entry code icon:



The 10 entry codes are displayed in the numerical order from 0 to 9. To modify or enter a code, click on "Modify". To skip an entry code without modifying it, click on the button:



To delete an entry code, click on "Modify" and then on "OK". For entry code number 9, the button «Save» replaces the button «OK». In order to enter or modify an entry code, it is necessary to go through each entry code and then click on the Save button. To go back to the menu click on Menu. Going back to the Menu without clicking on the Save button, cancel all the modifications made previously.

Note: The entry codes and the password must begin by the A or B letter followed by 4 numbers.

## H. Time delays

Click on time delay to modify the door open delay, the key-in keypad time delay, the console time delay or the value of the elevator relay board:

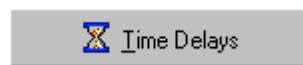

To modify the door open delay, click on "Modify", and then enter the time delay between 1 and 99 seconds.

Click on "OK" to validate the door open delay (modified or not) and go to the key-in keypad time delay.

To modify the time delay of the keypad, click on the button "Modify", and then enter the new time delay value, between 15 and 99 seconds.

Click on OK to confirm the new key-in keypad delay (modified or not) and go to the display unit time delay.

To modify the time delay of the display unit, click on the button "Modify", and enter the new time delay value, between 30 and 99 seconds.

Click on OK to confirm the new time delay of the display unit (modified or not) and go to elevator relay board time delay setup.

To modify the time delay of the elevator relay board, click on the button "Modify", and enter the new time delay value, between 01 and 99. This value is in tenth of seconds 01=10 seconds.

Click on the button "Save" to confirm all the time delays.

To go back to the Menu, click on the button "Menu".

### Note:

It is important to click on the "Save" button before leaving the time delays menu. Therefore, you have to go through the 4 time delays even though only one must be modified.

## I. New & Edit resident file

To enter, modify or delete a resident file, click on the button:

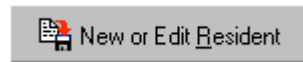

### 1. New resident

Enter the apartment number (between 000 and 999) of the new resident:

Apartment Number (000-999) :

Click on the button OK to confirm the apartment number. Then, enter the resident name; the name must not exceed more than 12 characters.

Resident name (12 characters) :

Click on the button OK to confirm the name of the resident.

If the Dip-switch No. 1 is ON:

Enter the floor number (00 or between 01 and 56):

Floor number (00 or 01-56) :

Click on the button OK, to confirm the floor number.

Then, enter the relay number (corresponds to the handset in the apartment) between 001 and 345:

Relay Number (001-345) :

Click on the button OK to confirm the relay number.

If Dip-switch No. 2 is OFF:

Access 4.3.2.1.P (0 or 1) :

- The first digit corresponds to reader No. 4,
- The second digit corresponds to reader No. 3,
- The third digit corresponds to reader No. 2,
- The fourth digit corresponds to reader No.1,
- The fifth digit corresponds to electronic directory panel reader

All the readers are authorized by default (1); replace the 1 digit by 0 to forbid the selected readers.

Click on the button OK to keep the same values or after the modifications.

NOTE: Make sure that there is five numbers before you click on the button OK.

Up to 8 badges can be programmed in each resident file.

Badge Number :  Status :

First badge processing :

The window above shows the processing of the first badge. This badge is valid (next to status the V stands for valid). If the badge is not valid, the field "Status" is empty.

Three choices:

- Delete badge
- Replace badge
- Keep badge

To enter the first badges or code, click on the button "Replace badge" and then present the badge in front of the badge programming unit (badge enroller), or else enter the badge code number via the keyboard:

**Present the badge in front of the Recording Reader**  
or  
**Enter the badge code :**

To enrol the first badge, click on the icon  then present the badge in front of the reader of the programming unit or enter the code from the keyboard.

Once the code of the badge is displayed in the box or entered manually press enter to save it.

Note : To program a PIN code for a keypad with a 4-digit code, enter 6 zero followed by the 4-digit code.

To program a PIN code for a keypad with a 5-digit code, enter 6 zero followed by the 5-digit code.

To program a proximity badge, a contact badge, an Infrared remote control or a magnetic stripe card, enter the code of the badge preceded by as many zeros in order to form a 10-digit code.

To program a RF code, enter R in capital letter as the first digit code, followed by 10-digit code. Complete the 10-digit code with zero. Example: If the code on the remote control box is 100804 the code to enter is R0000100804.

If there isn't any other badge or code to enter then click on the button



During the processing of the badges, at any moment click on the button "Next" to complete the file even though the all-8 badges were not entered.

To enter the other badges follow the same steps as for badge 1.

Once the 8 badges are processed, click on the button "Next", to enter or modify another resident.

Click on "Menu" to come back to menu.

## ***2. Edit resident file***

To modify a resident, enter the apartment number and click on the button OK.

The resident name is displayed:

Resident name (12 characters):

Change the name of the resident and click on OK to move to the floor number:

Floor number (00 or 01-56):

Change the floor number and click on OK to move to the relay number:

Relay Number (001-345):

Change the relay number and click on the button OK:

Access 4.3.2.1.P (0 or 1):

Change the status of the readers and click on the button OK

Badges:

Badge Number:  Status:

First badge processing:

Click on the button "Delete badge" to remove an existing badge.

Click on the icon "Replace badge" and present the new badge in front of the programming unit or enter the new code:

**Present the badge in front of the Recording Reader**  
or  
**Enter the badge code:**

To enrol the first badge, click on the icon  then present the badge in front of the reader of the programming unit or enter the code from the keyboard.

Once the code of the badge is displayed in the box or entered manually press enter to save it.

Note : To program a PIN code for a keypad with a 4-digit code, enter 6 zero followed by the 4-digit code.

To program a PIN code for a keypad with a 5-digit code, enter 6 zero followed by the 5-digit code.

To program a proximity badge, a contact badge, an Infrared remote control or a magnetic stripe card, enter the code of the badge preceded by as many zeros in order to form a 10-digit code.

To program a RF code, enter R in capital letter as the first digit code, followed by 10-digit code. Complete the 10-digit code with zero. Example: If the code on the remote control box is 100804 the code to enter is R0000100804.

If there isn't any other badges or code to program then click on the button

During the processing of the badges, at any moment click on the button "Next" to complete the file even though the all-8 badges were not entered.

To enter the other badges follow the same steps as for badge 1.

Once the 8 badges are processed, click on the button "Next", to enter or modify another resident.

Click on "Menu" to come back to menu.

### ***3. Deleting a resident***

To delete a resident, enter the resident apartment number and click on the button OK. The resident name is displayed on the screen. Click on the button Delete Resident to cancel the resident name.



The window apartment number is displayed again:

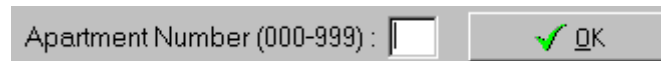

Click on the button "Menu" to return to the menu or enter another apartment number if you wish to enter, edit or delete a resident.

#### **Note:**

The button Esc which



appears while entering, modifying a resident name and a relay number allows to quit the without saving the new change on the file. Click on the icon Menu to come back to menu or click on the icon Next to create a new resident, edit a resident file or delete a resident file.

## **J. Resident List**

Click on the icon Resident List to display the resident directory list:



The first page of the resident list is displayed on the screen:

CDVInternational													
<i>Resident List</i>													
Resident List   Apart #   Floor #   Relay #   Total Valid Badges													
Donaldson	004	01	003	1	Reynolds	001	02	004	2	eric	000	00	001

Page 01  
Teleprocessing

Next Page>

Menu

The information related to a resident is displayed on 5 columns. In the first column the resident name is displayed, in the second one its apartment number, in the third column the floor number, in the fourth column the relay number and the in the fifth column the total badges which are valid for that particular resident.

Note:

The apartment number given to a resident doesn't have to be the same as the relay number used to activate the handset in the resident apartment.

To display the following page of the resident directory list click on the icon Next Page:

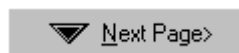

To display the previous page of the resident directory list click on the icon Previous Page:

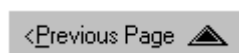

Click on "Menu" to go back to the menu.

## K. Stand by Message

Click on standby message to enter in the standby message menu:



Click on the icon "Modify" to edit the message.

Click on "Save" to save the new message.

Click on "Menu" to go back to the menu.

## L. Badge Identification

To identify a badge click on the button:

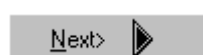

Then click on the icon "Next".

The following appears on the screen:

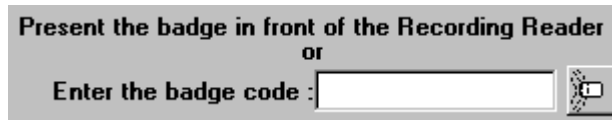

If you are using the badge-programming unit, click on the button  and present the badge in front of the programming reader. The code number of the badge is displayed in the blank space. Press **"Enter"**, to send the code to the directory panel.

If you are entering the badge code number from the keyboard, once entered press **"Enter"** to confirm the badge and to send it to the directory panel unit.

If the badge is not valid, the message not valid badge is displayed:

**Unknown Badge**

If the badge is valid the information on the resident are displayed:

- Resident name,
- Apartment number,
- Relay number,
- Total badges valid,
- The badge number which was identify (1 to 8),
- Badge status("V" for valid).

Click on the icon "Next" to identify another badge.

## M. Access Control

To install, delete or replace a reader click on the Access Control icon:

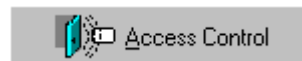

The Access window is display :

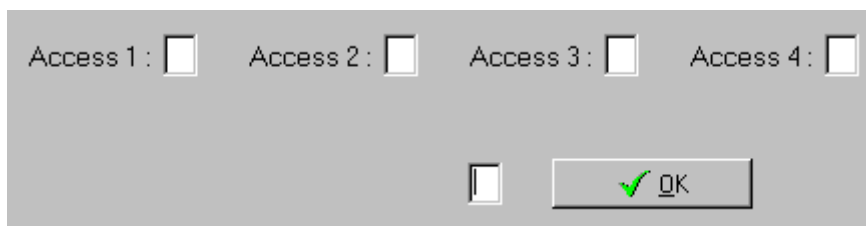

The reader was never installed if the box next to access is blank,

The reader is installed if a V appears in the box next to access.

The reader was deleted if there is an X in the box next to access .

To install, replace or delete a reader enter the number of the access in the box next to Process access number and click on OK.

The following window appears on the screen:



To add a reader click on the icon "Install" the access number that was selected must be blank to add a reader with the Add icon. Make sure that the reader is connected and

switched on LED green flashing. Put the ST1 jumper in position 2-3 installation mode the LED turns to red. Click on Install. The LED turns green, put back the jumper on position 1-2 normal mode the LED turns to orange flashing.

The message installation problem appears when the icon Add is clicked and that for an access number that contains a V or X, or when the reader is not properly connected.

To replace a reader click on the "Replace" icon. The message installation problem appears if the access was never used. Put the ST1 jumper in position 2-3 installation mode the LED turns to red. Click on Install. The LED turns green, put back the jumper on position 1-2 normal mode the LED turns to orange flashing.

Click on "Delete " to remove a reader. The message installation problem appears if the access is empty.

Important :

Make sure that the reader is connected and switched on LED green flashing. Put the ST1 jumper in position I (2-3) installation mode the LED turns red. Click on Install. The LED turns green, put back the jumper on position N (1-2) normal mode the LED turns to orange flashing.

## V. INDEX

### A. C16D RELAY BOARD

#### ENCODING ADDRESS OF BOARD

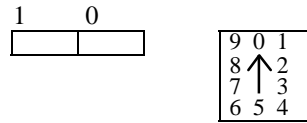

#### Address Setting

ADDRESS	RELAY No. 1 to 16	TENTH	UNIT
00	001 to 016	1 0 <input type="checkbox"/> <input checked="" type="checkbox"/>	0
01	017 to 032		1
02	033 to 048		2
03	049 to 064		3
04	065 to 080		4
05	081 to 096		5
06	097 to 112		6
07	113 to 128		7
08	129 to 144		8
09	145 to 160		9
10	161 to 176	1 0 <input checked="" type="checkbox"/> <input type="checkbox"/>	0
11	177 to 192		1
12	193 to 208		2
13	209 to 224		3
14	225 to 240		4
15	241 to 256		5
16	257 to 272		6
17	273 to 288		7
18	289 to 304		8
19	305 to 320		9

#### TERMINALS

C	COMMON
1	RELAY 1
2	RELAY 2
3	RELAY 3
4	RELAY 4
5	RELAY 5
6	RELAY 6
7	RELAY 7
8	RELAY 8
9	RELAY 9
10	RELAY 10
11	RELAY 11
12	RELAY 12
13	RELAY 13
14	RELAY 14
15	RELAY 15
16	RELAY 16

NOTE : All the C16D relay boards have as address default 00.

**B. BCM/384*****1. Configuration of the relays on the mother board***

ADDRESS	RELAY No (1 to 16)	COMMON	UNIT
1	001 to 016	C1	0
2	017 to 032	C1	0
3	033 to 048	C1	0
4	049 to 064	C2	0
5	065 to 080	C2	0
6	081 to 096	C2	0
7	097 to 112	C3	0
8	113 to 128	C3	0
9	129 to 144	C3	0
10	145 to 160	C4	0
11	161 to 176	C4	0
12	177 to 192	C4	0

**BCM/384 Mother Board 0*****2. Configuration of the relays on the mother board***

ADDRESS	RELAY No (1 to 16)	COMMON	UNIT
1	193 to 208	C1	1
2	209 to 224	C1	1
3	225 to 240	C1	1
4	241 to 256	C2	1
5	257 to 272	C2	1
6	273 to 288	C2	1
7	289 to 304	C3	1
8	305 to 320	C3	1
9	321 to 336	C3	1
10	337 to 345	C4	1

**BCM/384 Mother Board 1**

**C. Possible configurations**

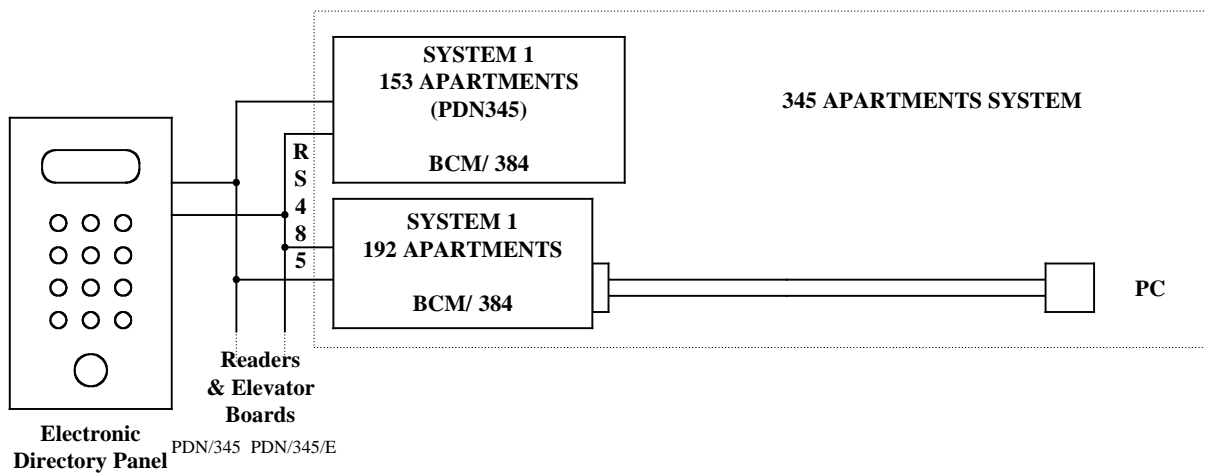
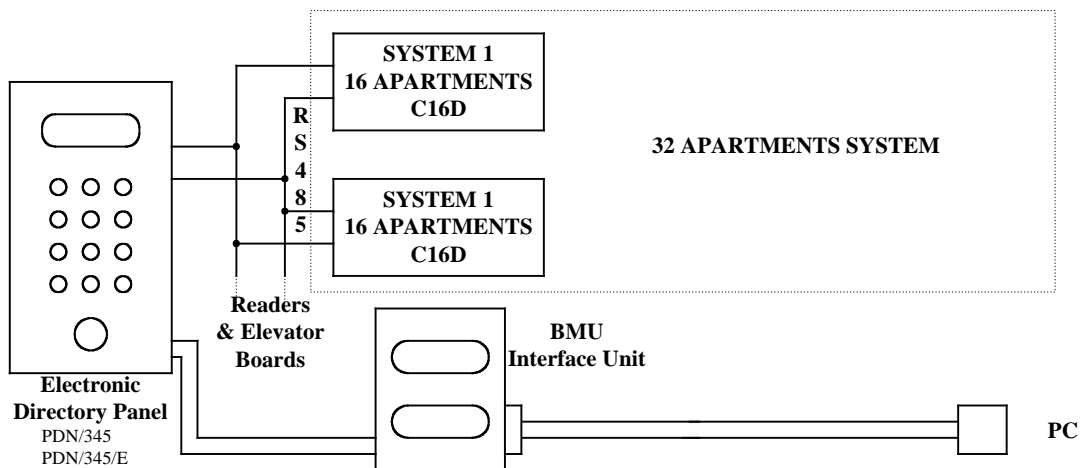
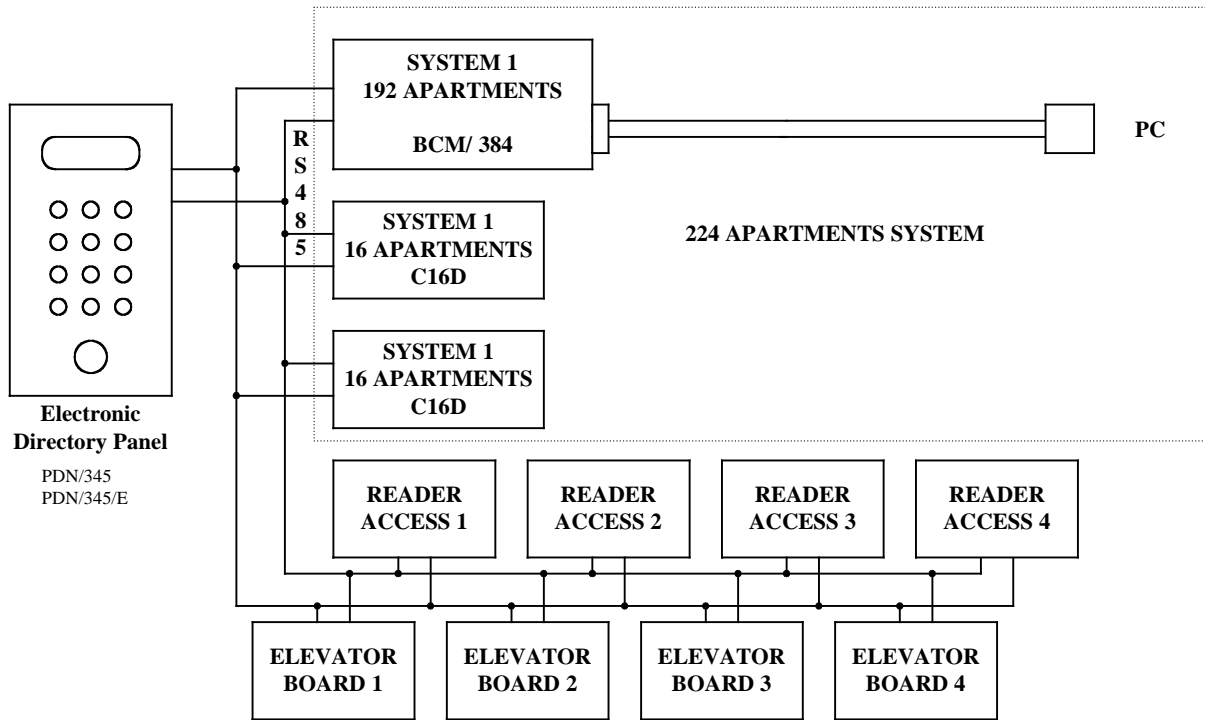

**D. Wiring diagram for BCM/384**

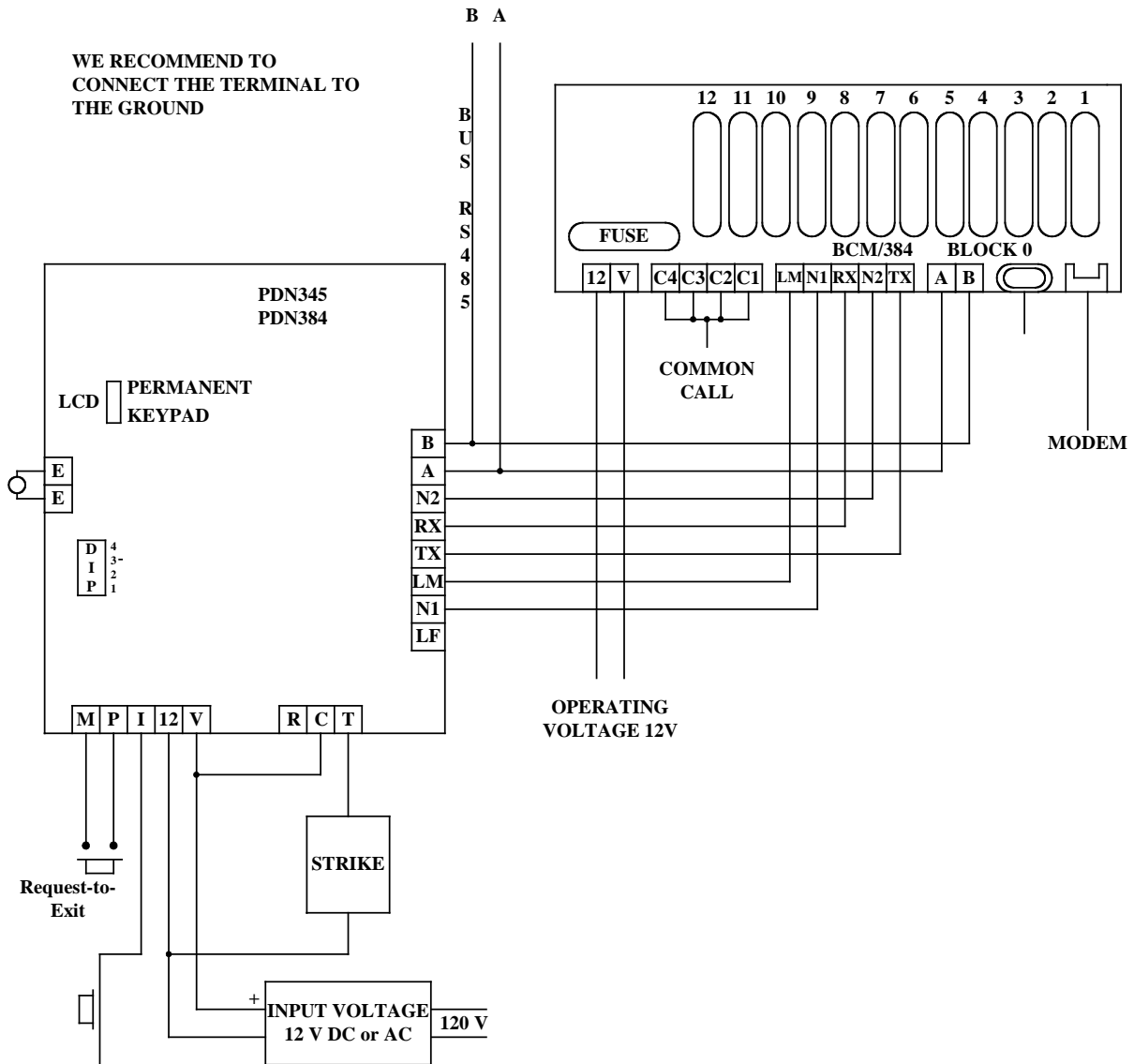

WE RECOMMEND TO CONNECT THE TERMINAL TO THE GROUND

OPENING COMMAND BY ENTRY-PHONE

Level (-) Common GND with the operating voltage of the PDN345, PDN384

- NOTE : - PUT THE 120 Ω RESISTANCE (SUPPLIED) BETWEEN A & B THE FAREST C16D CARD.
- PUT A CABLE "ARMED TWISTED PAIR" FOR THE BUS RS485

**E. Wiring diagram of C16D relay board and interface module BMU**

**Wiring Diagram of C16D and BMU interface module for PDN345/C PDN384**

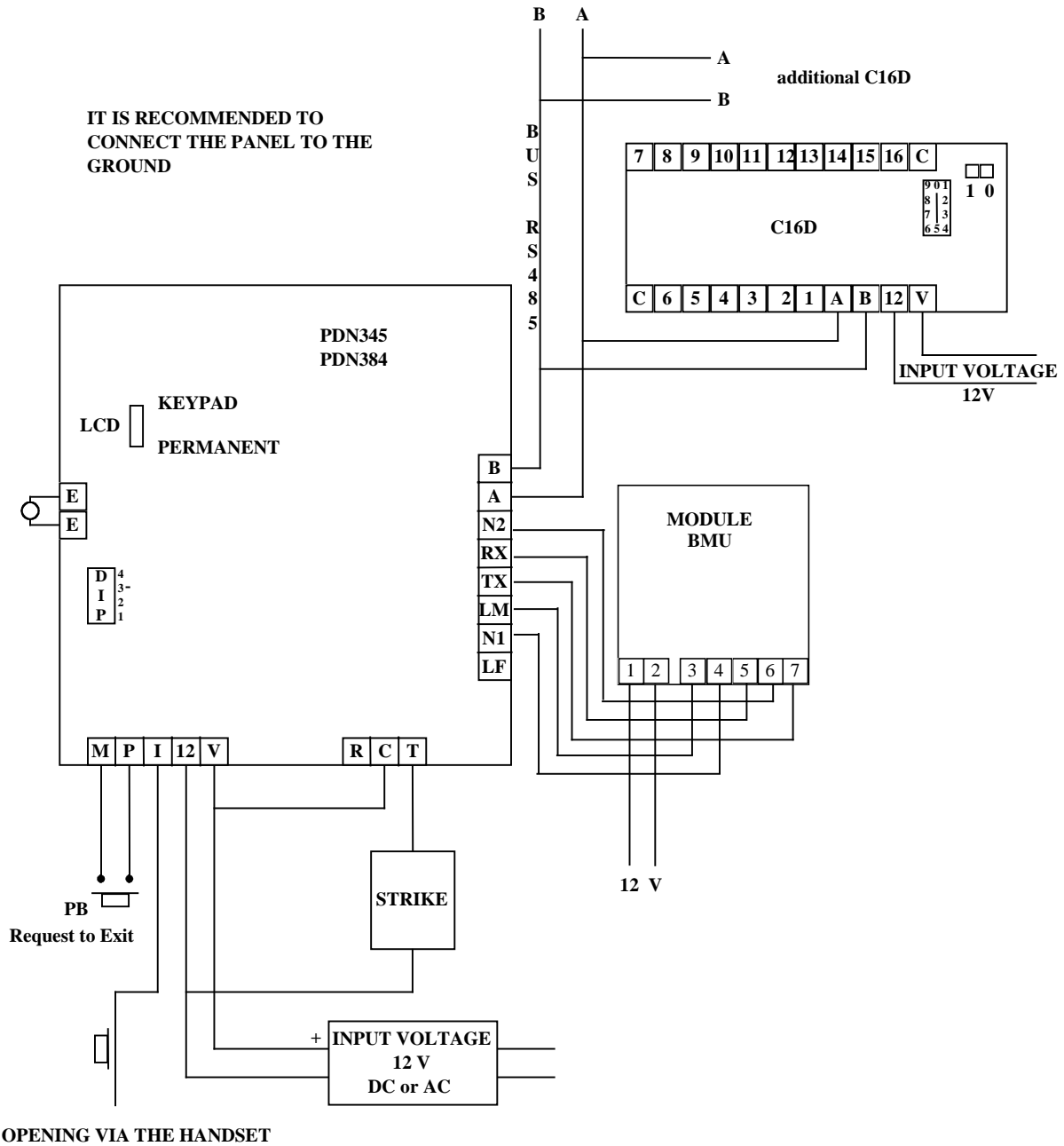

**NOTE** -INSTALL THE RESISTOR (INCLUDED) OF 120  $\Omega$  BETWEEN A & B OF THE LAST C16D BOARD  
 - USE A TWISTED CABLE SCREENED FOR THE RS485 BUS

**F. BMU Interface Module**

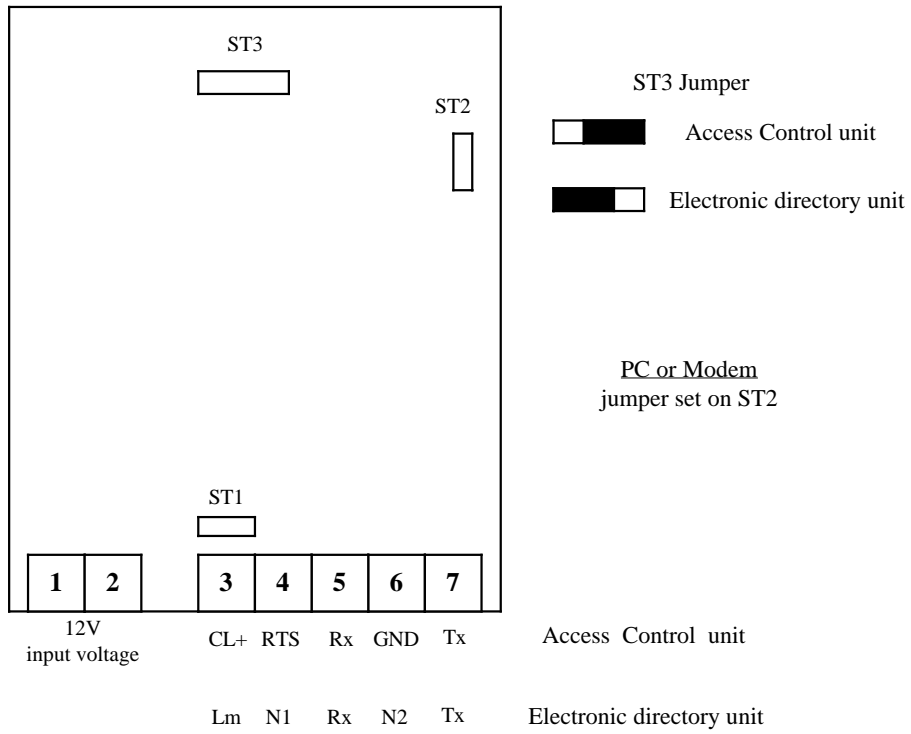

## G. READER Terminals

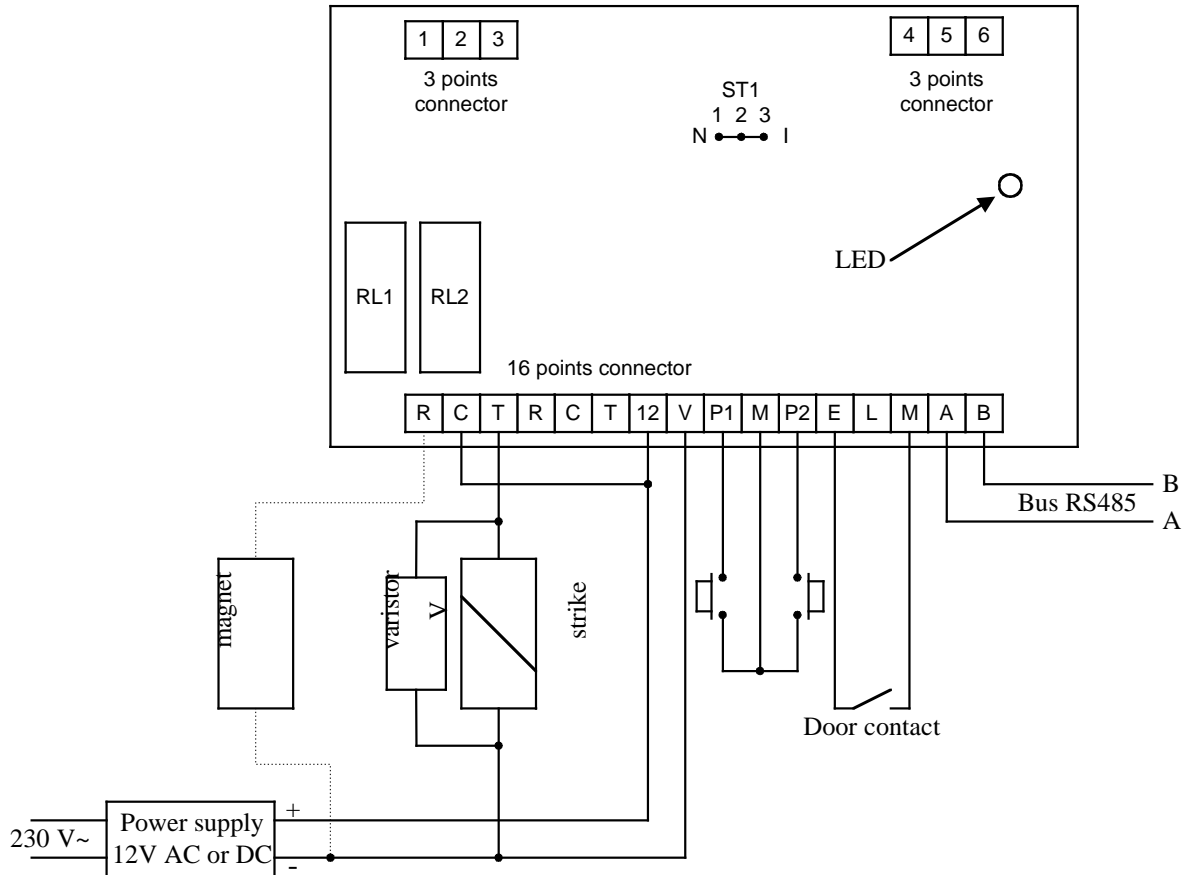

### 1. LED status

Installation mode: LED Red: ready to be installed

LED Green: reader installed (put back the jumper on normal position)

Normal mode: LED Orange flashing: normal mode

LED Orange: default in the connection between the reader and the  
PDN/345/C/PROX

LED Green: relay activated

LED Red: Forced open door or door left open (door ajar)

LED Green flashing: reader not installed or deleted.

### 2. 16 point terminal

R N/C contact alarm

C common

T N/O contact alarm

R contact N/C door magnet (+)

C common + power supply

T N/O contact door strike

12V power supply 12 V DC or AC

P1 Exit push button (REX)

M common

P2 External push button

E N/C contact door closed,

L reserved

M common

If the door contact is not used, short circuit E and M of the terminal.

A bus RS485 (all A must be wired between them in chain)

B bus RS485 (all B must be wired between them in chain)

**3. 3 point terminal 1,2, 3 & 4, 5, 6**

**a) Contact Badge**

- 1 terminal 1
- 2 terminal 2
- 3 not used
- 4 terminal 4
- 5 terminal 5
- 6 terminal 6

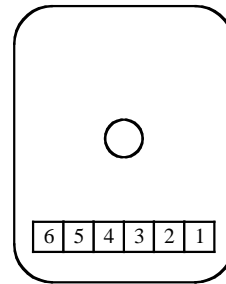

**b) Keypad**

- 1 keypad -
- 2 keypad +
- 3 empty
- 4 empty
- 5 empty
- 6 empty

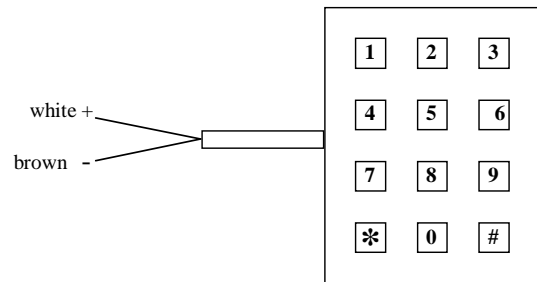

On the PCB of the reader, there are two different jumpers (ST1 and ST2) :

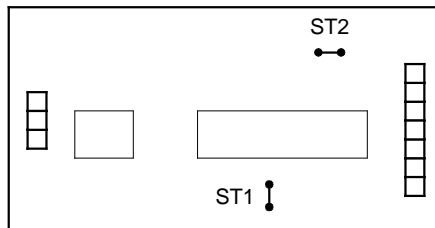

ST1 with the jumper: 5-digit access code

without the jumper: 4-digit access code  
 ST2 with the jumper: buzzer enabled  
 without the jumper: buzzer disabled

### c) Proximity

- 1 antenna terminal 1
- 2 antenna terminal 2
- 3 Not used
- 4 antenna terminal 4
- 5 antenna terminal 5
- 6 antenna terminal 6

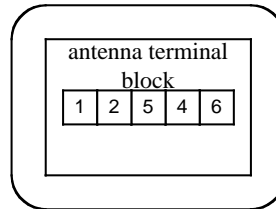

#### IMPORTANT:

- In case of using two proximity readers in/out on the same door, it is recommended to keep a minimum distance of 20 cm between them in any direction. In case the separation is inferior to 20 cm, the two readers must be moved from each other vertically or horizontally.

### d) Infrared

- 1 terminal 1
- 2 terminal 2
- 3 terminal 3
- 4 terminal 4
- 5 terminal 5
- 6 terminal 6

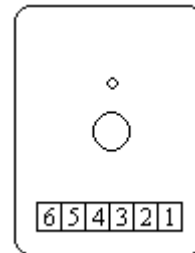

**e) Proximity LMPI/D or LMP/D extended distance (50m max)**

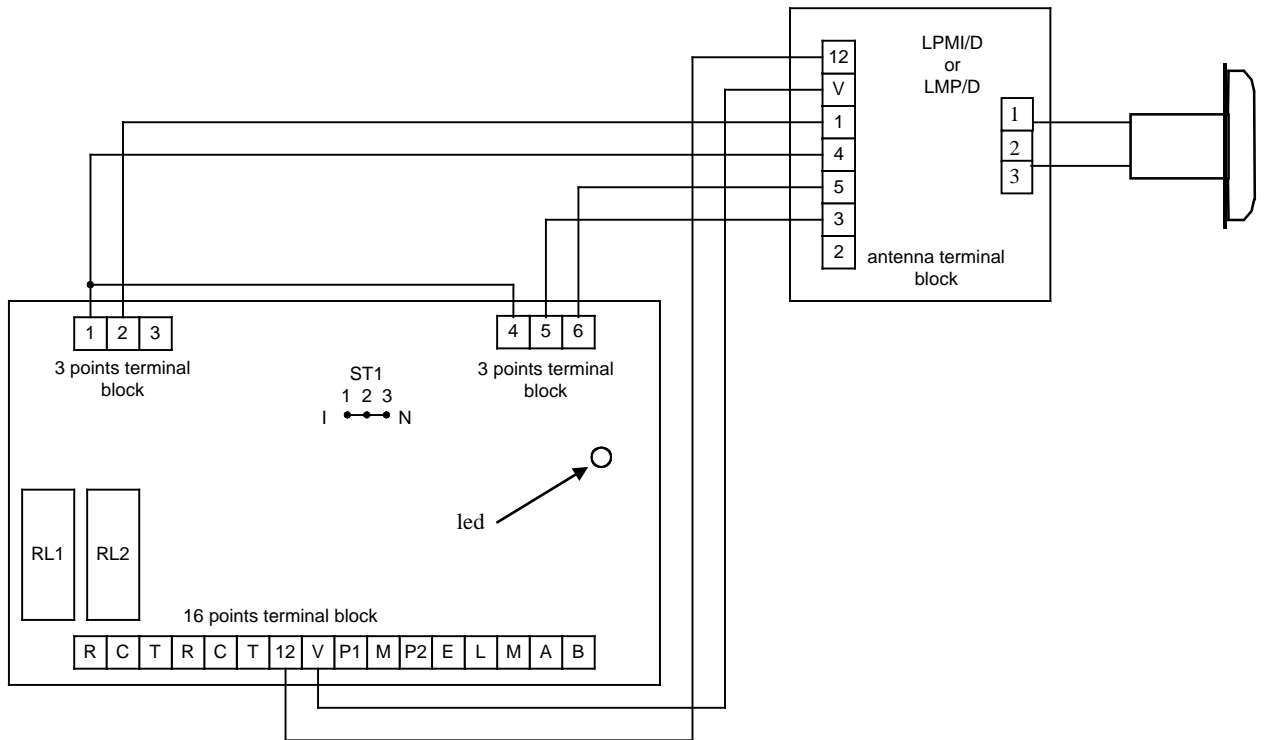

Recommended wire : 3 pairs cable SYT1 9/10 mm

**IMPORTANT:**

- In case two proximity readers in/out are installed on the same door, it is recommended to keep a minimum distance of 20 cm between them in any direction. Otherwise if the separation is under 20 cm, the two readers must be moved from each other vertically or horizontally.

**f) Magnetic stripe reader (format Clock & Data)**

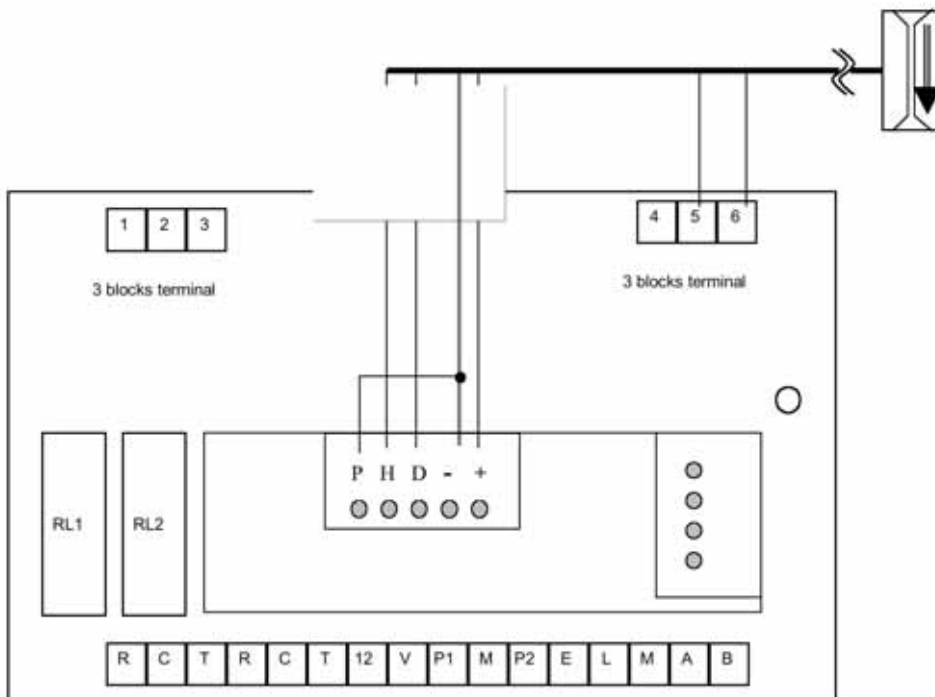

#### 4. Jumper ST1

Jumper in position 2-3 : installation mode

Jumper in position 1-2 : normal mode

##### a) RF reader

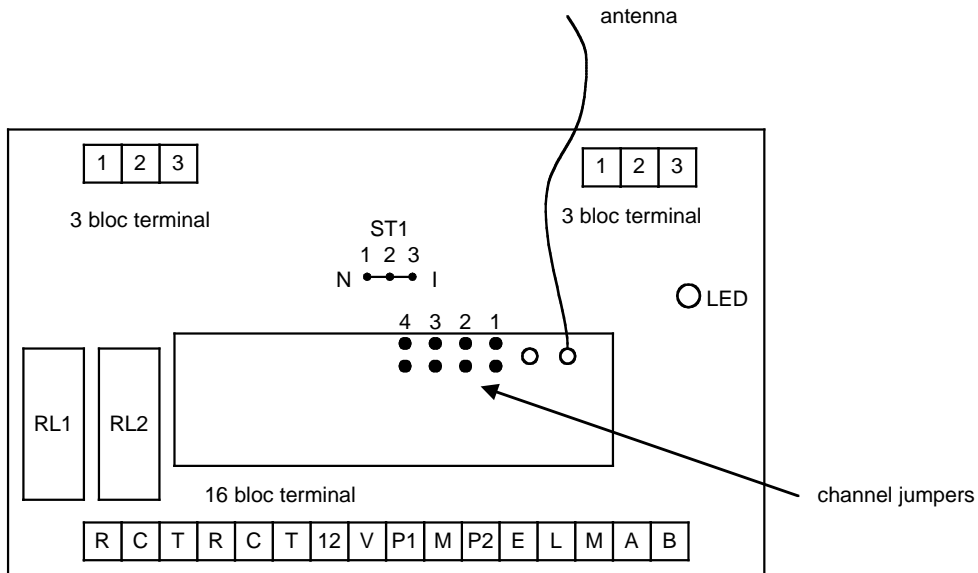

the RF reader comes in a plastic enclosure. To select one of the 4 channels insert the jumper:

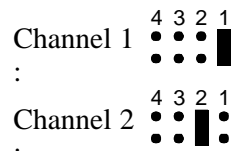

Replace the antenna if there is any problem receiving the signal from the remote (cable of 0,22 mm<sup>2</sup> , length 17,3 cm).

#### 5. Jumper ST1

Jumper position 2-3: installation mode

Jumper position 1-2: normal mode

#### 6. Reader default values

Door opened in case a communication problem

Forced open door 1 second

Door ajar (door left open) after 5 minutes

#### 7. Reader set on the elevator board

The first reader controls automatically all the elevator relay boards. It must be mounted in the elevator cage.

Once a valide badge is presented to the reader, all the relays are activated on the elevator board and then it authorizes to go to any floor.

## H. Elevator Relay Board

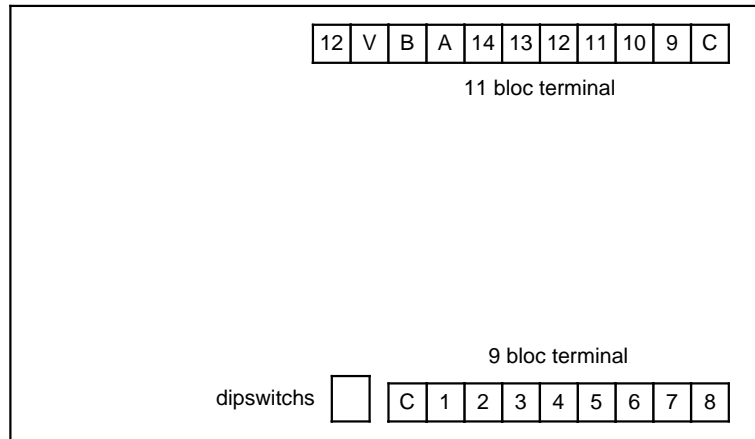

### 1. Configuration of the elevator boards

Set dipswitches 1 and 2 according to the board number:

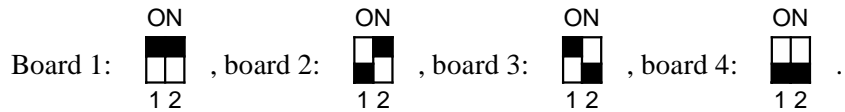

(Switch in position ON: )

Board No.	Floor
1	01 to 14
2	15 to 28
3	29 to 42
4	43 to 56

### 2. Terminal

C	COMMON
1	RELAY 1
2	RELAY 2
3	RELAY 3
4	RELAY 4
5	RELAY 5
6	RELAY 6
7	RELAY 7
8	RELAY 8
9	RELAY 9
10	RELAY 10
11	RELAY 11
12	RELAY 12
13	RELAY 13
14	RELAY 14

A: bus RS485

B: bus RS485

12 V: input voltage DC or AC 12V

The relays on the elevator board are N/O contacts (normally open).

### I. Badge Programming Unit

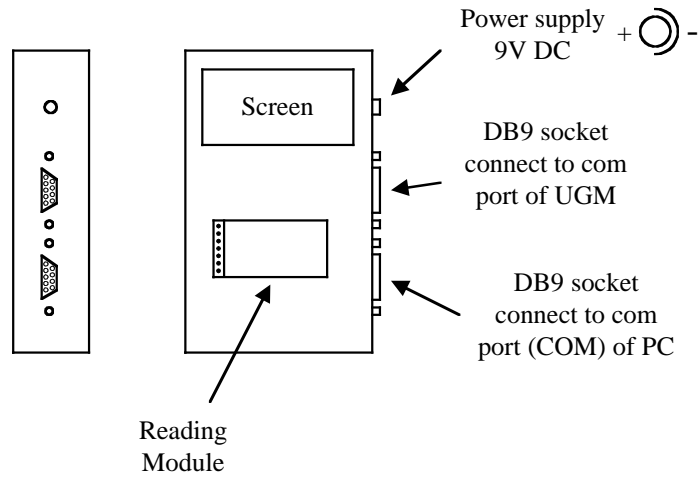

Present the badge in front of the reading module. The badge code is transmitted to the PC and displayed on the screen. When it is not being used as a programming device the unit displays the badge code number.

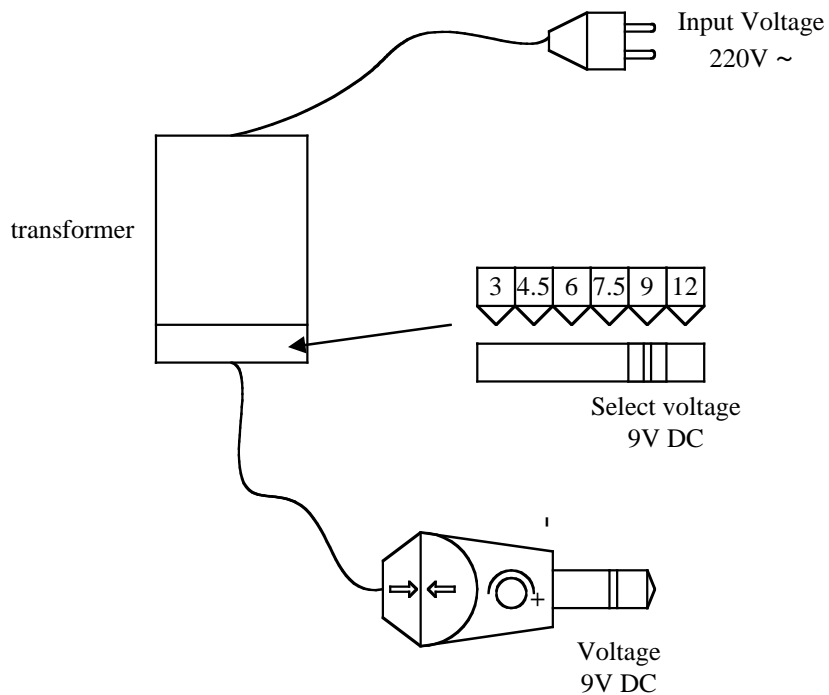

Earth the panel casing

To another board



**Sd: Shielded Cable**

**R : N/C contact**  
**C : Common**  
**T : N/O contact**

Refer to a more detailed wiring diagram for each unit

**NC : Not Connected**

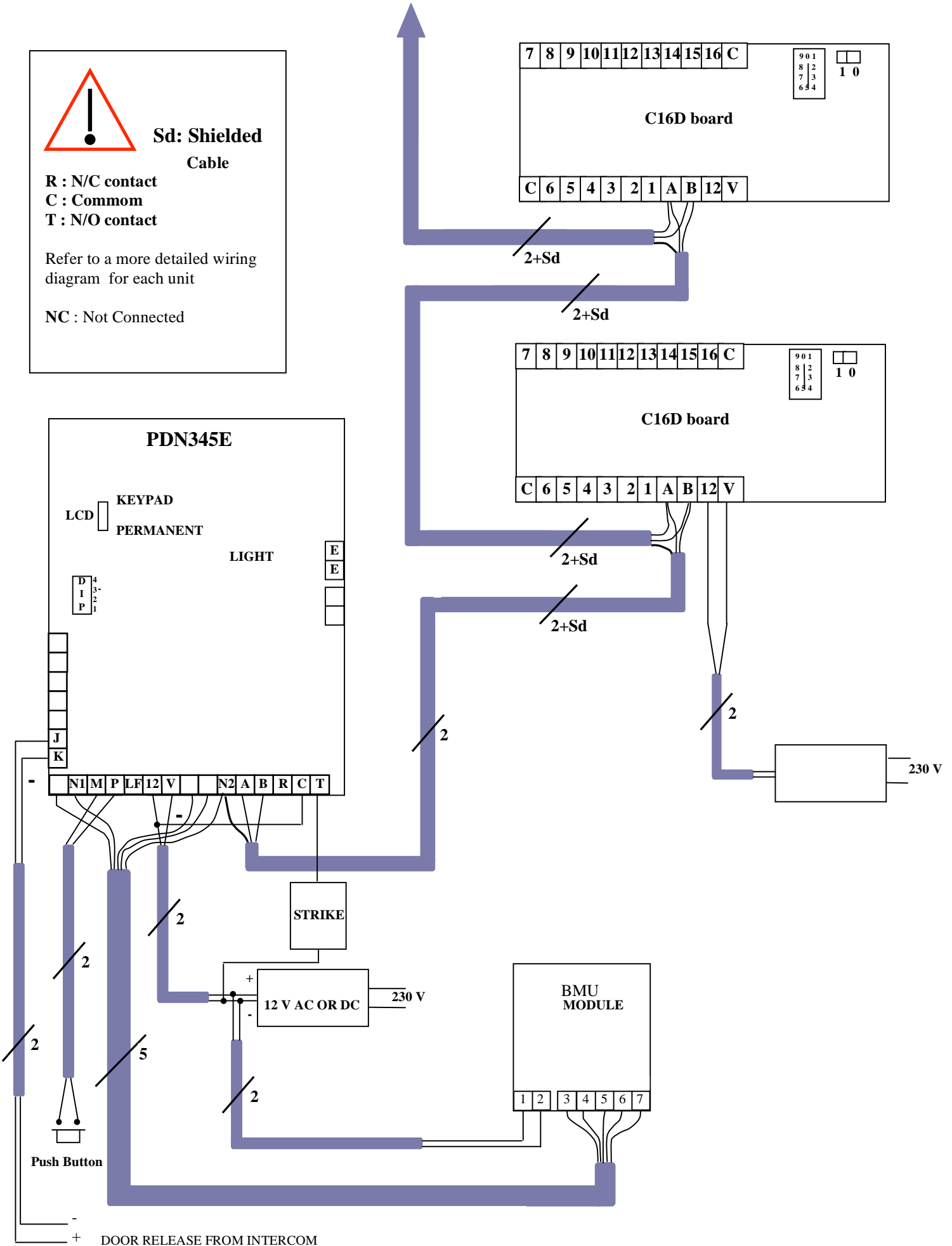

NOTE : The 120 Ω resistor must be installed on the last unit of the RS485 BUS line. Recommended cable 1 twisted pair shielded 9/10 MM or 1 twisted pair shielded AWG 20)